

New Theory of the Aether. By T. J. J. See.

(Sixth Paper.) (With eleven Plates.)

Part I. The Wave-Theory of Chemical, Explosive, and Vital Forces.

I. The Laws of Nature indicate that Chemical Affinity and Explosive Forces depend on Wave-Action.

General introductory remarks. In the fifth paper on the new theory of the aether (AN 5130) we have treated of the principal molecular forces — such as surface tension (which gives the globular figures to all liquid drops), adhesion, capillarity, cohesion, the tenacity of solids, etc. — but reserved for the sixth paper a more detailed study of the theory of chemical affinity, explosive forces, and the so-called living forces, which depend principally upon chemical action. It has long been believed by chemists that chemical affinity is an electrical phenomenon.¹⁾ Accordingly, if this could be proved it would follow also that explosive forces and the chief vital forces are electrical in character, depending in some way upon the action of waves in the aether.

On account of the great importance of the problem of atomic forces and the profound obscurity in which it has been veiled, we have labored first to make out the nature of the molecular forces. This course was chosen in the hope of finding principles deduced from phenomena under actual measurements of small distances, as in the thickness of soap bubbles, which might enable us to penetrate into the still smaller and more invisible mechanism of the atoms.

Without elaborate argument it would seem fairly obvious that if we could definitely refer such molecular forces as surface tension, capillarity, cohesion, to wave-action, another step in the same chain of reasoning should enable us to grasp the still finer mechanism on which the atomic forces depend.

For experience shows that nature is moderately continuous in her processes; and, judged by the distances at which they act, it is but a step from the molecular forces to the atomic forces. Accordingly the best preparation for a study of the forces operative in the structure of the atoms is the wave-theory of the molecular forces already outlined in the fifth paper. Admitting the probability that the proofs there given of the wave-theory of molecular forces are perhaps yet to be somewhat perfected, we hold nevertheless that so powerful an array of evidence as we have presented justifies our adoption of the wave-theory as a working hypothesis. So powerful an argument drawn from such a variety of phenomena, all mutually confirmatory in character, it seems to me, can only rest upon the basis of substantial physical truth. But in order to strengthen the evidence already adduced we cite the great authority of *Arrhenius*, in the chemical

phenomena of dissociation, *Lectures on Theoretical Chemistry*, University of California, 1904, p. 146:

»In the study of the so-called 'abnormal' vapour densities we have already found that some molecules, for instance those of ammonium chloride, are split up into two (or more) simpler molecules on raising the temperature. This process is called dissociation. The laws of dissociation were first studied by *St. Claire Deville*. Dissociation is a so-called reversible process, i. e. on lowering the temperature the products of dissociation re-combine. A chemical equilibrium exists between the original molecules and the products of their decomposition, and the study of the laws of this equilibrium may be effected by the help of thermodynamics. This study has been very fruitful for theoretical chemistry, and we will, therefore, consider the phenomenon of dissociation a little more in detail.«

»The simplest case [of dissociation] is that presented by the molecules of iodine, which at low temperatures are composed of two iodine atoms and at higher temperatures are split up into simple atoms, as the molecular weight determinations by *Victor Meyer* (Ber. 1880, 13.394) and *Crafts*, (Compt. rend., 1880, 90.184), have made evident.«

Arrhenius thus distinctly points out that when elements are dissociated, one of the most effective modes of uniting them into molecules made up of more than a single atom is to lower the temperature. In this way, when the longer heat waves are withdrawn, the atomic forces, depending on the shorter waves, become powerful enough to group the atoms into pairs or higher combinations as molecules.

Following the same principles, all the so-called permanent gases have been liquified or solidified under combinations of very high temperatures with very great pressures. Air, oxygen, hydrogen, and finally helium have been reduced to the liquid or solid state, by a process similar to that above outlined by *Arrhenius* as applicable to chemical bodies generally.

In view of these considerations, it is evident, on physical grounds, that the great processes of nature are essentially uniform and continuous. If therefore, we withdraw heat — which is a phenomenon of long wave-action — to enable the atomic forces to assert themselves for the formation of molecules of two or more atoms, it is natural to infer that the cause of the molecular and atomic forces is similar to the heat waves by which they are overcome. It would be remarkable if heat-waves should release forces not due to waves of any kind.

Accordingly, we are led directly to the wave-theory of molecular and atomic forces. And it is very difficult to see how so obvious and simple an argument can be evaded.

¹⁾ Voltaic or dynamic electricity was excited by the force of chemical action in the primitive experiments of *Galvani*, at Bologna, 1790, and their immediate development at Pavia, by *Volta*, who made use of plates of zinc and copper, as in modern batteries.

As *Mossotti* says at the close of the introduction to his celebrated memoir *Sur les forces qui régissent la constitution intérieure des corps*, Turin, 1836:

»C'est un argument qui me paraît mériter beaucoup d'intérêt, parce que la découverte des lois de l'action moléculaire doit conduire les géomètres à construire sur un seul principe la mécanique moléculaire, comme la découverte de la loi de l'attraction universelle les a conduits à ériger sur une seule base le plus beau monument de l'intelligence humaine, la mécanique céleste.«

In alluding thus to *Mossotti's* theory of molecular and atomic forces, published 85 years ago, we think it well to point out that this theory has some similarity to the wave-theory, but also very notable differences which we cannot now go into, except very briefly.

As the particles of material bodies are not in actual contact, *Mossotti* supposes that each is surrounded by an atmosphere of the aethereal medium, which he conceives to be electricity.¹⁾ He assumes that the atoms of the medium repel one another, that the particles of matter also repel one another, but with less intensity; and thus there is a mutual attraction between the particles of matter and the atoms of the medium, under forces which vary inversely as the square of the distance.²⁾

From this theory it follows that when the material molecules of a body are inappreciably near to one another, they mutually repel each other with a force which diminishes rapidly as the infinitely small distances between the molecules augment and at last vanishes. When the molecules are still farther apart, the force becomes attractive. At an intermediary distance the repulsive and attractive forces balance, so that if we try to press the particles nearer the repulsive forces resist our attempt, while if we try to break the body, the attractive forces predominate and hold them together.

The wave-theory presents to our contemplation quite a different picture of the physical world. All forces are attributed to stresses in the aether due to wave-action, and we seek to inquire under what conditions the stresses or forces arise; and we find that boundary conditions exercise the largest influence in changing the velocity and direction of waves, and thus give rise to adhesion, cohesion, capillarity, chemical affinity, and the other molecular and atomic forces.

In his address as rector of the university of Berlin, Oct. 15, 1913, quoted in the fifth paper, section 12 (ii), (AN 5130), Professor *Planck* points out that in the breaking up of the aether waves a limit of smallness or length is finally attained,

owing chiefly to the finite size of the atoms of matter. Have we not here an indication of the short waves which act to prevent compression of solids?

1. As we have seen in AN 5048, p. 140-41, resistance breaks up long waves into shorter ones. Now if the process of wave disintegration finally stops, as *Planck* says it does, there must be an influence at work to counteract the breaking up of the waves.

2. This can only be the limiting wave lengths corresponding to the dimensions of the atoms. To make the waves shorter would tend to disrupt the aether between the atoms. And as the forces required for the disruption of a medium 689321600000 more elastic than air in proportion to its density, would be nearly infinite in magnitude, vast stresses always are at work between the atoms and molecules, both attractive and repulsive.

3. The central stress yields enormous power of cohesion, and thus the hardness of diamond and the tenacity of steel become intelligible. On the other hand, the finite dimensions of the atoms limit the reduction of the wave lengths, by forces equally powerful, and hence the incompressibility of solids and liquids.

As *Laplace* was careful to point out, these molecular and atomic forces are sensible only at insensible distances, which suggests that wave-action under the enormous elasticity of the aether as the source of the power.

(i) As chemical affinity is shown by laboratory experiments to be promoted and increased by the action of ultra-violet light, this fact of observation must be held to be a proof that it depends of wave-action.

We cite the following experiments as well calculated to illustrate this subject. In each case the interpretation appears to be simple and unique, and thus the experiments are well adapted for disclosing the nature of the chemical changes involved.

(a) Decomposition of chloride of silver or nitrate of silver by light in photography. This is a very familiar phenomenon and has been known since the days of *Daguerre*, *Talbot*, and *Herschel*, who first developed photography over 80 years ago. In this experiment, the chloride of silver, either recently formed or carefully protected from the shorter waves of light, is exposed to the action of common light, which contains the waves of the whole visible spectrum. As is well known a partial decomposition of the silver chloride results from the action of the light; and the action of the short waves is so much more powerful than that of the long waves,

¹⁾ »It has long been an hypothesis among philosophers that electricity is the agent which binds the particles of matter together. We are totally ignorant of the nature of electricity, but it is generally supposed to be an aethereal fluid in the highest state of elasticity surrounding every particle of matter« — Mrs. *Somerville*, *Connexion of the physical sciences*, 6th edition, 1842, p. 120.

Sir *Isaac Newton* held somewhat similar views, but could not work out the causes involved to his entire satisfaction; yet he did foresee the possibility of the kinetic theory of the aether, and clearly held that universal gravitation is due to impulses of this subtle aethereal medium. As we now are able definitely to establish the cause of universal gravitation, by following the sagacious suggestions of *Newton* we deem it only just to include the portrait of this most illustrious philosopher as a frontispiece to this sixth paper on the New (Kinetic) Theory of the Aether.

²⁾ »Professor *Mossotti* has recently shown by a very able analysis, that there are strong grounds for believing that not only the molecular forces which unite the particles of material bodies depend on the electric fluid, but that even gravitation itself, which binds world to world and sun to sun, can no longer be regarded as an ultimate principle, but the residual portion of a far more powerful force generated by that energetic agent which pervades creation.« — Mrs. *Somerville*, *Connexion of the physical sciences*, 6th edition, 1842, p. 121.

It will be noted that in these papers, we have not treated of the repulsive forces of the particles of matter in liquids and solids, as *Mossotti* has attempted to do, except to imply that the resistance to compression probably depends on short wave motions of the same type to which molecular forces are due.

that when a plate has been exposed and is not yet developed or fixed by the action of the hyposulphite of soda we may examine the plate under a light transmitted through red glass, which allows only the longer waves to pass. The hyposulphite of soda dissolves readily chloride, bromide, and iodide of silver, and has been generally used in photography since the days of *Daguerre*, 1840.

By the action of the shorter waves of light on the film containing the salt, $AgCl$, the chlorine is separated and the silver partially precipitated, so that a change of color from white to blue occurs in the film; and as the change over the plate is proportional to the action of the light on that part, photography gives the shades, or aspects of objects about as they appear to the eye in common vision.

The very chemical change which we use in photography we utilize in our vision; but the retina of the eye, being a living film, has its power of reaction renewed by certain natural processes, and only the images are transmitted to the brain, with the chemical changes continually in progress. Thus if chemical action be electrical, it is undoubtedly true, as Sir *Oliver Lodge* remarks, (*Aether of Space*, 1909, p. 25) that »Sight is probably a chemical sense«. Hence the eye is sensitive to aether waves of a certain length, and capable of transmitting their chemical or mechanical effects, in producing images, to the brain.

(b) A considerable variety of chemical solutions are used in photography, but the general effect is always the same, and hence we content ourselves with the simplest outline of the changes, without going into further details. In his thoughtful work on the Correlation and Conservation of Physical Forces, p. 115, (New York, 1883) the English physicist Professor *W. R. Grove*, of the Royal Institution, London, gives the following account of the effects of light upon bodies:

»The effect of light on chemical compounds affords us a striking instance of the extent to which a force, ever active, may be ignored through successive ages of philosophy. If we suppose the walls of a large room covered with photographic apparatus, the small amount of light reflected from the face of a person situated in its centre would simultaneously imprint his portrait on a multitude of recipient surfaces. Were the cameras absent, but the room coated with photographic paper, a change would equally take place in every portion of it, though not a reproduction of form and figure. As other substances not commonly called photographic are known to be affected by light, the list of which might be indefinitely extended, it becomes a curious object of contemplation to consider how far light is daily operating changes in ponderable matter, how far a force, for a long time recognized only in its visual effects, may be constantly producing changes in the earth and atmosphere in addition to the changes it produces in organised structures which are now beginning to be extensively studied. Thus every portion of light may be supposed to write its own history by a change more or less permanent in ponderable matter.«

(ii) The experiments of Sir *Humphrey Davy* in the decomposition of the alkaline earths under the action of electric currents explained by the wave-theory.

A great epoch in the history of experimental chemistry was made by Sir *Humphrey Davy's* decomposition of the

alkaline earths, in the first decade of the 19th century. We shall attempt to show the relationship of these experiments to the wave-theory, and thus make somewhat clearer the nature of the chemical forces, which *Davy* overcame in these celebrated discoveries, by means of the action of the electric current.

When *Davy* began his career, the discovery of the decomposition of chemical substances by voltaic electricity had already begun to excite the interest of men of science; but although *Davy* developed the method most powerfully, and achieved brilliant discoveries, and more than a century has since elapsed, we still have no mechanical or dynamical theory of *Davy's* process of electrolysis.

In the third paper on the new theory of the aether we have proved that an electric current consists in a series of waves, usually quite long in character. Now if such waves be intense, the resulting rapid and violent agitation should obviously be well suited to separating or breaking up the molecules of a compound into its constituent elements. This is exactly what Sir *Humphrey Davy* did.

He had at his command a battery of 400 five inch plates, and one of 40 plates a foot in diameter. With these batteries were conducted his experiments on the alkaline earths, which resulted in the discovery of potassium and sodium.

In 1805 *Davy* began to use also very high temperatures, and in 1806 found that electro-chemical phenomena were explicable by one general law, the acids appearing at the positive, the bases at the negative pole. He generalized his conclusions by stating that hydrogen, the alkalies, earths, metals and certain oxides are attracted by negatively, and repelled by positively electrified metallic surfaces.

He then proceeded to investigate the law of electro-chemical action, and concluded that electro-chemical combinations and decompositions depend on electric attractions and repulsions; and that both »chemical and electrical attractions are produced by the same cause acting in the one case on the particles, in the other on the masses.« The discovery of potassium and sodium was made by electrical decomposition, in October, 1807.

Since we have already shown that an electric current consists of an ordered system of waves of various lengths, we may now be able to throw some new light on the composition and decomposition of bodies.

1. When the long electric waves are powerful and aided by partial breaking up into the shorter waves of heat, the wave agitation of appropriate length may become great enough to eject parts of a compound molecule to such distance that the atomic forces no longer can retain it in stability; in the rapid successions of the oscillations, some of the atoms fly away, anywhere along the line of the electrolysis, but with opposite elements appearing at the poles for the reason set forth in paragraph 6 below.

2. The atoms which are of one type, by their periodicities bearing a certain resonance to the waves, will naturally collect at one pole of the battery; those of very different periodicities and having a different resonance, will naturally gather at the opposite pole, in accordance with observation.

3. It is only when the electric waves, which are ordered in a certain way along the line of the current, become of a

certain intensity, aided by the shorter haphazard agitations called heat, that electrical decompositions can be expected to occur. Otherwise the shorter and more powerful waves which cause chemical forces are predominant.

4. It is to be observed that in electrolysis the electrolyte acts as a conductor, the circuit being completed by the wire connecting the poles. Around the wire the amplitude of the electric waves follow *Biot* and *Savart's* law

$$I = Ki/r \quad A = VI = V(Ki/r). \quad (1)$$

5. This makes the amplitude greatest next to the wire, and as the poles are terminals of the wire, it naturally follows that decomposition occurs where the wave agitation is a maximum, at the poles of the battery.

6. And as the waves lie flat in the planes through the axis of the wire, the separation will go on according to the rotation in the wave flow — one pole emitting the waves, the other receiving them — and thus the elements are sifted by the movement of the waves, according to poles. In the fifth paper, section 10, we have explained tenacity by increased surface effects due to wave-action at the boundary. Thus we have also solved the problem of cohesion of like elements in electro-plating, heretofore so difficult to natural philosophers.

(iii) Decomposition of water into oxygen and hydrogen gases by the action of an electric current; these elements again united by the action of short waves.

If we put the two poles of a battery arranged to terminate in platinum wire or sheet, into water slightly acidulated with sulphuric acid (H_2SO_4), so as to render the liquid a good conductor; and let the battery act we shall immediately perceive small bubbles of gas accumulating at each pole. When the experiment is arranged as shown in *Regnault's Elements of Chemistry*, (Philadelphia, 1860, p. 110), each pole being inserted in a tube which collects the liberated gas, it is found that the volumes of the gases released by electrolysis are in the ratio of 2 to 1, two volumes of hydrogen to one of oxygen, as shown in the cut.

It is found that the gas disengaged at the positive pole, is oxygen, that at the negative pole hydrogen — the volumes of gas developing in the precise ratio of 2 to 1, as shown in the figure. Thus one volume of oxygen serves for two of hydrogen in the formation of water, H_2O .

If now when the battery has decomposed the water into its two constituent gases, we collect the separated gases in one vessel, without any admixture of air or other foreign gases, the separate molecules of hydrogen and oxygen will be present in just the proportion to form water. And when the gases have become equably diffused, after mixing, an electric spark generated within the vessel as from the wire terminals of a battery, not quite in contact, where the gases are freely mixed, yields the sudden impulse for the union of the atoms of hydrogen with those of oxygen to form water vapor. It collects as drops on the walls of the vessel, and

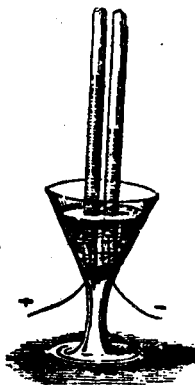

Fig. 1. Decomposition of water into oxygen and hydrogen by the action of an electric current.

trickles down, the amount being exactly equivalent to that decomposed by the original current.

Accordingly, by this experiment we learn that violent long wave agitation due to a current, may produce decomposition of water into its elements hydrogen and oxygen. And when the gases are carefully collected, and mixed, an electric spark, by the action of its short waves may again unite them into water.

If any free hydrogen is present in the atmosphere lightning operates to form from it with free oxygen a small quantity of water vapor. It is supposed that by the combustion of telescopic meteorites, billions of which are burnt up daily in the higher parts of the atmosphere, some free hydrogen is diffused in the air; and the action of lightning thus replenishes to some extent the water lost by permanent absorption in the rocks of the earth's crust. Whether the new water formed by lightning is equal to that lost from our oceans by absorption and crystallisation in the rocks of the earth's crust is not yet known; but it is supposed that during the historical period the two tendencies approximately balance each other, so as to maintain a nearly constant quantity of water on the earth.

(iv) *Priestley's* experiments for producing mercuric oxide (HgO) and the separation of these elements by the use of higher temperature illustrates the wave-theory.

On Aug. 1, 1774, *Priestley* discovered that the red oxide of mercury (HgO) evolved a gas when heated to a considerable temperature. The gas was oxygen and the residue left behind was metallic mercury.

In these celebrated experiments it was found that when metallic mercury in contact with air is heated to a temperature just below its boiling point, it gradually becomes covered with a red scale of mercuric oxide. And when this red scale is collected and subjected to considerably higher temperature, the result is the separation of the oxide into its constituent elements, oxygen gas, and metallic mercury.

Now this experiment in the composition and decomposition of a well known metallic oxide is typical of many oxides, and similar compounds.

1. When heat or molecular wave agitation is applied in not too violent a form, chemical combination results.

2. But when the molecular agitation is made much more extreme, by the use of higher temperatures, the compound is broken up. This is because the chemical affinity, under short wave action, is able to form combinations, when the heat agitation due to the longer waves is not too violent. But the moment the longer wave agitation becomes more extreme, the atomic hold is released, and the elements fly asunder, to form vapors and gases.

It is difficult to imagine a more convincing illustration of the wave-theory than that here presented to our contemplation. The chemical processes appear to be simple, and we can see the combination taking place, by moderate wave agitation, but released by the more violent form of molecular agitation incident to higher temperature.

This rule, for using changes of temperature for effecting chemical combinations and resolutions, has been so widely recognized by chemists that it may be said to be the most general process of that science. When a chemical body is to be broken up, we first try change of temperature. If that

does not succeed, we try the electric current. And frequently we use both high temperature, and the electric current, or some form of electric furnace, as developed about 30 years ago by the celebrated French chemist *Moissan*.

Of late years electro-chemistry has become a distinct branch of practical science, of the greatest importance in the arts, and industry. If the above line of reasoning be admissible, it follows that electro-chemistry depends on wave-action, by which artificial combinations of metals are effected usually under the joint action of a powerful current and a high temperature. The molecular structure of the atoms is so interwoven that when such mixtures as phosphor-bronze, aluminium-bronze, nickel-steel, or vanadium-steel are effected, they are found on cooling to have extraordinary strength, and therefore become extremely useful in the mechanical arts.

(v) Other examples of chemical combinations under the action of spongy platinum, or of ultra-violet light, which has short wave length.

1. It is well known that metallic platinum, especially the black or spongy platinum, condenses gases upon its surface, and furthermore the condensation is attended by the development of heat. This material is celebrated for occluding hydrogen or oxygen; and it has been inferred from the development of heat noted, that the spongy platinum by its cavernous structure acts to cause partial combination of hydrogen and oxygen similar to that noted in flame or ordinary combustion: that the spongy platinum probably does not itself directly produce the chemical combination, but that as the molecules of the gases are absorbed in the cavernous metallic structure, their mutual reactions are complex and condensation of the elements of the gas results. Probably this raises the temperature somewhat, — the result of the confined molecular agitation when the inrush of gases is first effected, — and then the power of absorption of the platinum increases with the rise of temperature.

2. The experiments in thermo-chemistry by *Berthelot* show that heat usually develops in chemical combinations.

It is found that ozone is formed in small quantities when water is decomposed by the electric current. It is formed in the air by lightning discharge, or near a frictional electric machine. In the conversion of oxygen into ozone, the volume of gas contracts by one-third, three molecules of oxygen furnishing two molecules of ozone thus:



When the ozone is again converted into oxygen, which may be done by heat, — the decomposition at 200° C. being very rapid — the original volume is restored. The use of heat to break up ozone into oxygen, perfect decomposition occurring before 300° C. is reached, shows that the triple molecule O_3 is rent asunder by the long wave agitation due to high temperature.

According to *Berthelot* no less than 29600 units of heat are evolved from 32 grammes of oxygen in the reaction:



And a corresponding amount of energy must be expended in the formation of ozone from ordinary oxygen. The conversion of ozone into oxygen, however, takes place in two

stages: first, the molecule O_3 is converted into $O_2 + O$; and second, the two free atoms of oxygen form two molecules of ozone, thus:

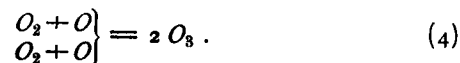

Oxygen has considerable affinity for itself in the form of common oxygen, O_2 , but relatively little for the third atom of oxygen, in the form of ozone. Hence ozone is a great oxidizer. The separation of the atoms of the oxygen molecules from each other involves 29600 heat units for 32 grammes of oxygen; but in the breaking up of ozone O_3 into $O_2 + O$ only a small amount of energy is required.

3. This use of heat for the formation of new bodies was first recommended by *Robert Boyle*, in the *Sceptical Chemist*, 1661. The modern science illustrates this theory by hundreds, yea, thousands of examples, of which we cite merely simple types. But it is only since the epoch of *Lavoisier* that the nature of combustion and the part played by oxygen has been understood.

It follows from the modern doctrine of energy, that if we can determine the heat evolved in combustion or any similar process, we have a numerical measure of the energy which must be expended to effect the corresponding decomposition of the elements previously united. Yet sometimes this energy may be made effective in one way, sometimes in another.

4. As far back as 1775 *Torbern Bergman* of Upsala wrote a dissertation on elective attractions, as he called affinity, and set forth that the compounds formed by the admixture of reagents depended on the sum of their attractions. It was *Lavoisier* (1743-1794), however, who gave a new spirit to chemistry, by devising methods for throwing new light on processes long known, but never before clearly understood. His theory of oxygen was not indeed adopted by *Berthollet* (1748-1822), yet it finally prevailed after the establishment of the mechanical theory of heat.

5. The discovery by *Faraday*, in 1834, that the decompositions effected by the voltaic current indicate the quantity by weight in which the elements combine, or the weights of the atoms according to the atomic theory, at once increased the probability of the hypothesis that the same operations are at work in both chemical and electrical phenomena. Out of this theory of electrolysis grew important developments in electro-chemistry. And when it was shown by *Laurent* that hydrogen may be substituted by an equivalent of chlorine or bromine, and the dualistic theory of positive and negative elements was shaken, *Berzelius* and others tried to reconcile this substitution of an electro-positive for an electro-negative element, by certain modifications of the dualistic theory, some compounds of oxygen as a fourth element being both an oxide and a chloride. The primitive distinctions for simple elements thus become modified for compounds.

(vi) Chemical affinity under wave-action related to explosive forces.

We now consider the chemical action of light and heat, which represent shorter waves than are present in the electric current.

1. It is noted that hydrogen does not spontaneously enter into reaction with any of the elements, though it has

a powerful affinity for some of them, such as oxygen. Accordingly when hydrogen and oxygen are mixed nothing occurs; but if a burning taper or a heated wire be applied, or still better an electric spark, a violent explosion follows, and the gases are united to produce water, $2H_2 + O_2 = 2H_2O$.

2. As energy is thus given out in the formation of water, it will naturally follow that energy must be expended on water to dissociate it into its constituent gases, whether by violent heat or the wave agitations of an electric current. This composition and decomposition of water thus beautifully illustrates the wave-theory.

3. Again, chlorine gas Cl_2 , and hydrogen gas H_2 , are each biatomic, and without action upon each other in the dark. But if the mixed gases be exposed to a bright light, especially a beam of ultra-violet light, or violently agitated by the passage of an electric spark, the gases unite with explosive violence to form hydrochloric acid. The reaction is shown to be:

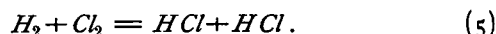

Evidently the formation of hydrochloric acid gas is preceded by the separation of the two atoms of the chlorine molecules, and of the two atoms of hydrogen in the hydrogen molecule, from each other; which calls for the expenditure of some energy; then follows a greater evolution of energy in the formation of HCl , or of H_2O in the case of water considered above.

4. The general result is that more energy is given out in the formation of the more stable compounds. The atoms of hydrogen have less affinity for themselves than for chlorine, and the chlorine has less affinity for itself than for hydrogen. Hence under wave agitation the mixed gases undergo the changes shown by the formula:

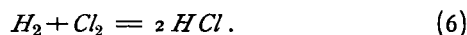

As soon as this change is started in a few molecules, the agitation thus set up spreads to the whole mass, and all the molecules are transformed into new chemical bodies, — namely water vapor, as described in paragraph 2 above, or hydrochloric acid gas, paragraph 3.

In the wave-theory of physical forces it is believed that the energy exhibited in chemical reactions is drawn from the unlimited storehouse of the aether everywhere pervading the universe. The chemical reactions therefore involve simply an exertion of this unseen power when the atomic rearrangement occurs, and the resistance to the passing waves is suddenly changed. The result is the exertion of unseen and unsuspected forces which frequently are explosive in character and often extremely terrible, as in dynamite, and other forms of nitro-glycerine, the tri-nitrotoluenes, and other high explosives.

2. Geometrical Arrangement of the Atoms as conceived by *Regnault* and others for explaining Crystals.

(i) The forces underlying the crystalline forms referred to the aether.

It has long been recognized by chemists that the atoms in certain molecules occupy definite relative positions. This is inferred partly from the chemical formulae of the substances, partly from the forms of the corresponding crystals, the study of their symmetry and the isomorphisms, both of special and of general physical properties, as tested by optical and magnetic methods. Indeed the study of crystallography is a very extensive branch of science, and much improvement has become possible of late years, since the Swiss physicist *Laue* began the use of X-rays for exploration of the internal structure of crystals.

This subject is now so extensive that only a general outline of results is permissible in a paper on the aether. We shall give therefore merely a sketch of the method by which the problem is attacked.

In the fifth paper on the new theory of the aether we were enabled to throw light on the powerful refractions, dispersions, and other disturbances experienced by the aether at the boundaries of bodies, by which this medium is placed under extraordinary stress, and we made it probable that the resulting reactions produce the observed hardness and tenacity of bodies.

1. It was shown in the first paper that the aether is 689321600000 more elastic than air in proportion to its density. Accordingly, if the waves traversing the universe be concertedly distributed, by a systematic arrangement of the atoms within the molecules, and of the molecules within crystalline bodies, — such a medium is well calculated to give crystals not only special and geometric forms, but also great hardness and other physical properties which have long caused crystals to be associated with magnetism, as offering extraordinary molecular, optical, magnetic and other physical properties.

2. We have also seen that magnetism depends upon concerted wave-action,¹⁾ and shown the physical and geometrical relationship of the waves to the electric current. And it is evident that if such powerful actions and reactions, which we can control in magnetism and electrodynamics, are due to concerted wave-action; then a corresponding, though differently arranged, stress of the aether should exist about crystals, in view of the atomic arrangement long recognized to exist, and made evident to the senses by *Laue's* X-ray photographs of crystalline structure.

3. We may say that crystals, so far as optical and physical properties are concerned, should present to our contemplation a kind of generalized magnetism. And this we find to be a fact, as shown by the elaborate researches of crystallographers such as *Voigt*, *Laue*, and others. The crystals have various axes of symmetry, and physical, optical and magnetic properties corresponding to the geometrical form of the crystals.

4. It is true that crystals of different substances, with the same geometrical form, have different physical, optical, and magnetic properties. This difference doubtless depends

¹⁾ In the outline of the wave-theory of magnetism, and electro-dynamics, AN 5044, p. 73-74, we refer to the collapse or expansion of the medium when the waves interpenetrate. The balance of the kinetic equilibrium of the medium at the same time involves vast exchange of the aetherons. This essential condition of the kinetic equilibrium is there assumed, but it should be borne in mind by those who may be inclined to overlook the foundations of the kinetic theory, which rest on incessant molecular exchange.

on the molecules which make up the crystalline structure. Molecules in which the atoms are held together by powerful affinities will naturally give rise to hard crystals; and thus, as some substances have great affinities between their atoms and molecules, strong resistance by the crystalline mass does not surprise us.

5. If the crystal is easily dissolved by heat, we should infer that increased agitation by these long waves tend to throw the atoms and molecules beyond the range of the shorter waves holding the atoms to the molecules, and the molecules to one another, for the make up of the crystal. If the crystal be difficult to dissolve by heat, then the opposite conclusion may be assumed.

6. Accordingly, the study of the physical properties of crystals will throw light on the properties of the molecules, and vice versa. Optical and magnetic properties bear similar relationships, but as yet they are little understood.

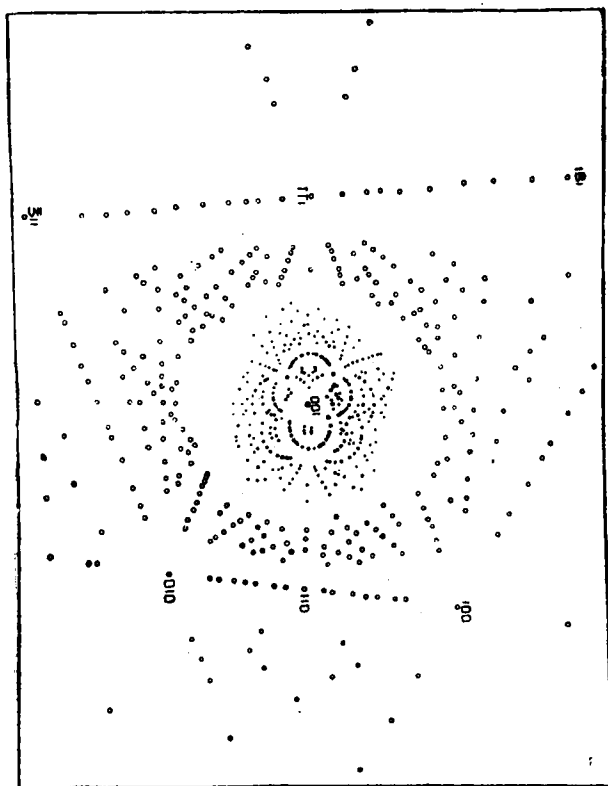

Fig. 2. Illustration of the *Laue* Radiograph of the arrangement of molecular structure in calcite (Iceland-spar), from an article by *R. W. G. Wyckoff*, Amer. Jour. of Science, Nov. 1920, p. 321.

(ii) Exhibition of the theory of crystalline structure conceived by *Regnault*.

The celebrated French chemist *Henry Victor Regnault* was one of the most careful and exact investigators of the middle of the 19th century. His *Elements of Chemistry*, in two volumes, (English translation by *Betton*, Philadelphia, 1860), not only is a model treatise on chemistry, but also contains very profound and sagacious remarks on the physical properties of all elements and their compounds, — so that it

lays the foundations of physical chemistry since more fully developed by *Berthelot*, *Moissan*, *Ostwald*, *Van't Hoff*, *Arrhenius* and others.

This is not the place to go into the details of chemical theory, but we may properly reproduce the sagacious outline of crystalline structure conceived by *Regnault*, and since elaborated, from different points of view, by *Voigt* and his followers, and recently confirmed by the photographic X-ray researches of *Laue* and the numerous investigators who have taken up his new methods for exploring crystalline structure.

Regnault begins his theory of crystals by the discussion of divisibility, and shows that however fine the mechanical division may be carried, it falls short of molecular and atomic sizes. In this connection it is well to recall *Newton's* remarks in the *Optics*, 1721, p. 365, »that it is difficult to conceive of the agency by which attraction is produced, when two smooth bodies are in very close contact, yet really touch or approximately touch only in a few points«. In the fifth paper on the new theory of the aether we built up a theory of molecular forces based on wave-action sensible only at insensible distances, because the waves are very minute.

After examining very profoundly the six systems of crystals and working out the numerical relations, often extremely simple, which exist between the faces, axes, and dimensions of the crystals, *Regnault* comes finally to the hypothesis of molecular decrements, (p. 44).

Regnault's reasoning quoted in detail:

»The laws of symmetry which exist between all the crystalline forms of the same substance, are very easily explained by starting with certain hypotheses on the form of the crystalline molecules and their mode of grouping. It is useful to study, at this time, these hypotheses, not only because they give us, as it were, material explanation of these laws, but also because, under their guidance, *Häuy* discovered, by induction, the laws of crystallography, which he afterwards verified by measurement. Let us take a mineral substance, as galena, which crystallizes according to the regular system, and assumes many forms of this system. Let us, in the first case, examine a cubic crystal of galena (fig. 3a, plate 1). If we endeavour to fracture it by violence, or by applying a cutting edge, in various directions, we shall soon find that the crystal cleaves, very readily, in three directions parallel to the faces of the cube, whilst it resists all others. The fragments thus detached from the cubic crystal, as well as the remaining nucleus, have all the forms of rectangular parallelepipeds. This mechanical division may be carried very far, for the little fragments may be further divided, and the microscope will show the most minute dust to be composed of rectangular parallelepipeds. We are naturally led, by induction, to infer that the ultimate crystalline particles, that is, those which resist cleavage, will affect the same form. These particles are therefore called integral crystalline molecules, each one of which is formed of a great number of chemical molecules, separable, perchance by other mechanical means, and grouped together by means of forces hitherto unexplained.«

»Let us now take an octahedral crystal of galena (fig. 3b, plate 1). If we endeavour to cleave it in a direction parallel to its faces, we shall not succeed. We obtain, on the contrary,

a very ready cleavage in the direction of planes equally inclined toward the four faces comprising the solid angles of the octahedron. By effecting these successive cleavages at all the solid angles, we shall soon destroy its octahedral form and obtain a nucleus in the form of a rectangular parallelepipedon, which continued cleavage will diminish, but not alter its cubical form. We therefore conclude that the crystalline molecules of the octahedric crystal, as well as those of the cubic crystals, are small rectangular parallelepipedons.*

»Let us select, in the last place, a crystal of galena presenting the form of rhombic dodecahedron (fig. 3c, plate 1). We shall again find that this crystal does not cleave in a direction parallel to its faces. The only natural cleavages are in the direction of planes equally inclined toward the faces of the 4-sided solid angles *A*. If we effect successive cleavages on the six 4-sided solid angles, we shall destroy the faces of the dodecahedron, and obtain nuclei having the form of rectangular parallelepipedons, resembling in appearance and the physical properties of their faces the nuclei we obtained from the cubic and octahedric crystals. We are therefore led to conclude that the crystalline molecules composing the dodecahedric crystal have the same form of rectangular parallelepipedons as those of cubic and octahedric crystals.*

»But what is the ratio of the lengths of the sides of this primitive parallelepipedon? We will observe that the three directions of cleavage which lead to this parallelepipedon present no feature distinguishing them from each other: they are equally easy, and the faces they produce have the same lustre. We are therefore induced to admit that the three dimensions of the parallelepipedon are equal, and that it is consequently a cube. The crystalline particles of galena are therefore cubes, and, if induction has not deceived us, we can reproduce, by the juxtaposition of these small elementary cubes, the cube, the octahedron, the rhombic dodecahedron, and, in short, all the crystalline forms of galena. We are about to show that this can be readily effected.*

»In order to render the fact more apparent, we shall greatly exaggerate the dimensions of the small elementary cubes. This we may do without invalidating the accuracy of the demonstration, for we only consider the tangent planes, the directions of which remain the same, whatever may be the dimensions of the integral crystalline molecules, provided that their forms and mode of grouping be the same. The cubic crystal will be directly formed by the juxtaposition of the elementary cubes. Let us place, on the several faces of the cube *abcdef*, (fig. 4a, plate 2), strata of cubic molecules, arranged as they are in the cubic crystal itself; but suppressing, in each stratum, a row parallel to each side of the face of the cube, so that each new stratum shall contain, on each side, one row less than the preceding. It will be readily seen that we thus obtain the rhombic dodecahedron (fig. 3c, plate 1). Fig. 4a proves this fact: in order not to complicate this figure and destroy its general aspect, we have suppressed the lines which mark the separation of the juxtaposed elementary cubes; but we have indicated them on fig. 4b, plate 2, which represents, on a greater scale, one of the solid angles of the new formation.*

»By supposing the cubic molecules to be infinitely small, the asperities arising from the subtraction of the rows will disappear, and the faces of the dodecahedron will become perfectly plane. We may therefore say, that the rhombic dodecahedron is derived from a cube by the decrement, on the faces of the cube, of a row in length and a row in height.*

(iii) *Regnault's* theory of the removal of rows of elementary particles.

»Let us now suppose that from each new stratum we remove 2, 3, or 4 rows of elementary particles; it is evident that we shall produce, on each face of the cube, 4-sided pyramids, of which the elevations will be $\frac{1}{2}$, $\frac{1}{3}$, or $\frac{1}{4}$ of the axis of the cube, and that we shall obtain the various tetrahedrons (fig. 3d, plate 1) mentioned in the paragraph above. We shall thus have effected a decrement of 1 row in height, and 2, 3, or 4 rows in length.*

»Let us now take a large cubic crystal (fig. 4c), and, starting from the centre of one of its edges, and symmetrically as regards its conformation, remove a molecule from the first upper stratum, 2 from the second, 3 from the third, we shall obtain a tangent truncation of the solid angle of the cube. Repeating the process on each of the angles, we shall have a regular octahedron (fig. 4d) formed by the decrement of a row in length, and a row in height on the angles of the cube.*

»Let us now return to our cube *abcdef* (fig. 4e), and add to its faces additional strata of cubic molecules; but let us make, following the edge *fe*, a decrement of 2 rows in length and 1 in height, and, following the edge *fd*, a decrement of 1 row in length and 2 in height, we shall obtain the pentagonal dodecahedron (fig. 4e). We have omitted in this figure the lines of separation of the small elementary cubes; but these lines are seen in the fig. 4f, which represents, on a larger scale, the anterior portion of fig. 4e. The pentagonal dodecahedron is a hemihedral form, a hemi-tetrahexahedron (Fig. 3d): the other hemihedral forms of the regular system are obtained in the same manner, by unsymmetrical decrements on similar edges.*

»It will be easily seen, without multiplying examples, that we can reproduce, by analogous additions or subtractions, all the figures of the regular system.*

»It can be shown that all the forms of the second system of crystallization may be constructed with crystalline molecules having the figure of a right parallelepipedon, with a square base, but of which the elevation is not equal to the length of the sides of the base; the ratio between this elevation and the sides of the base being always identical in the same substance, but differing in different substances.*

»Let us take a crystal having the form of a right prism with a square base, and add to its base strata of crystalline molecules, with a decrement of a row in length and a row in height in the direction of the sides of the base: we shall obtain a square-based pyramid, of which the elevation will present, to the sides of the base, the same ratio as the homologous lengths of the crystalline molecule. Treating the inferior base of the prism in the same manner, we shall obtain a right square-based prism, terminated by two pointings, which, united by their bases, form a square-based octahedron. Assuming this octahedron as the primitive octahedron of the

T. J. J. See. New Theory of the Aether.

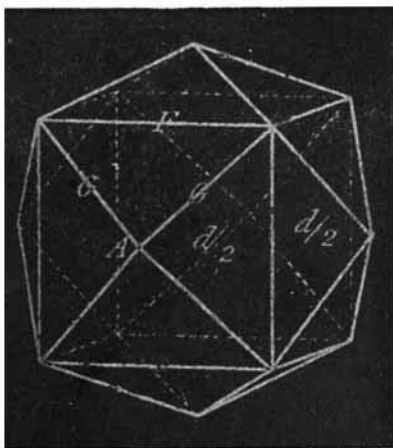
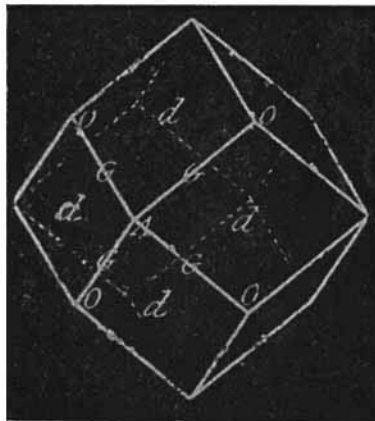
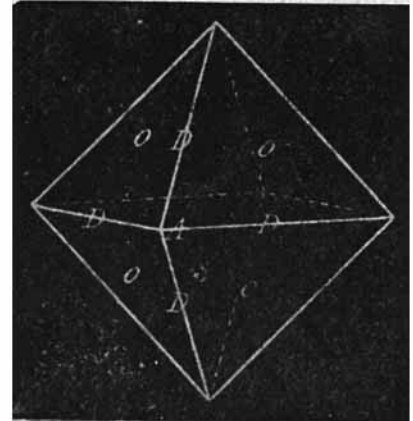
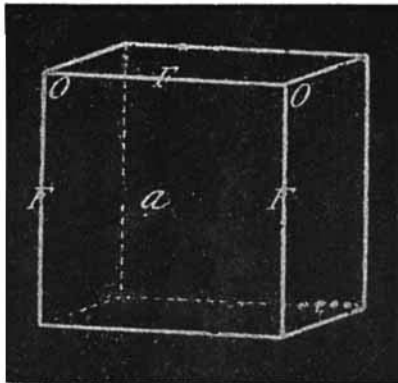

d

e

Fig. 3. a, b, c, d, e. *Regnault's* theory of the geometrical arrangement by which the atoms give the molecules the property of infinitesimal elements for building up crystals.

T. J. J. See. New Theory of the Aether.

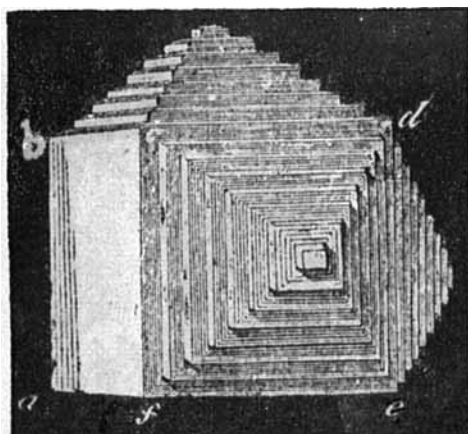

a

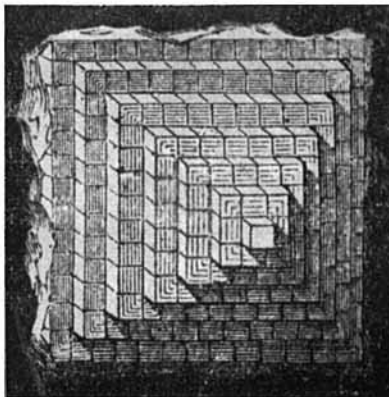

b

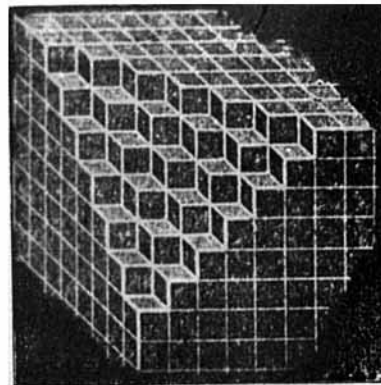

c

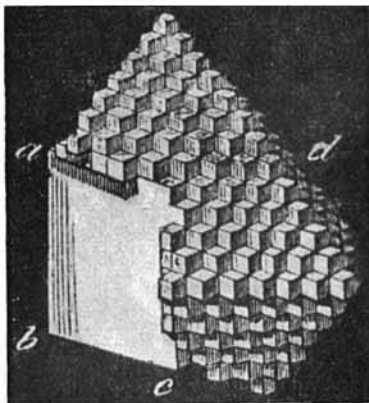

d

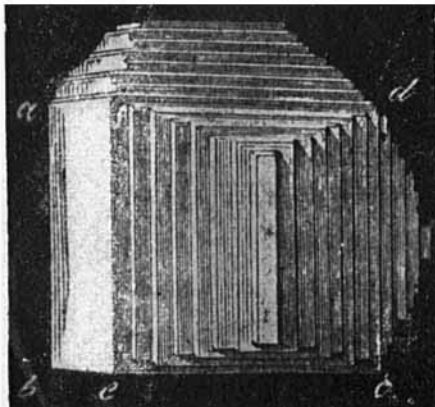

e

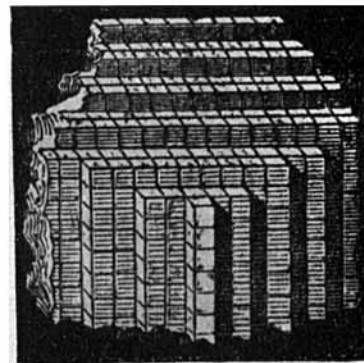

f

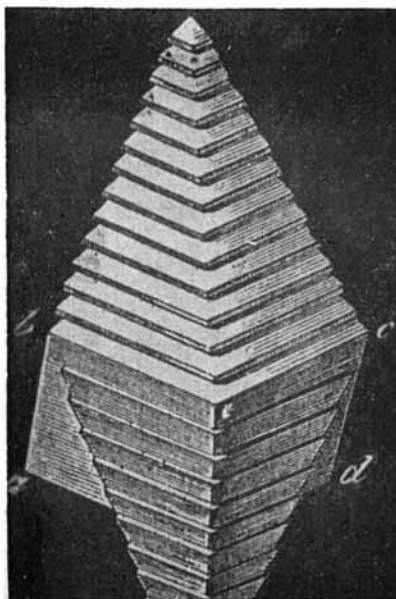

g

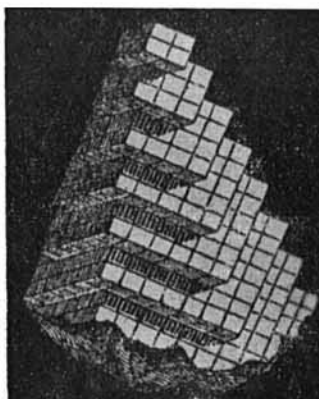

h

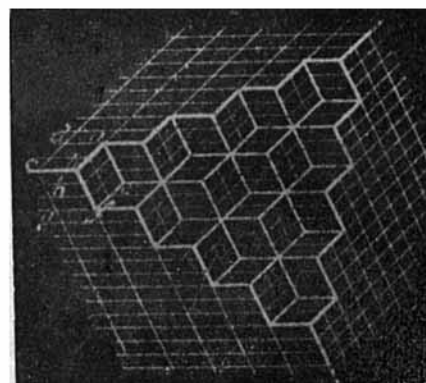

i

Fig. 4. a, b, c, d, e, f, g, h, i. Further details of *Regnault's* theory of crystal building, by the addition of molecules with geometrical atomic structure.

substance, its dimension will immediately indicate those of the integral crystalline molecule.«

»We may construct on the same base other 4-sided pyramids by making decrements of 1 row in length, and 2, 3, or 4 rows in height. We shall thus have octahedrons with square bases, more and more acute, of which the elevations will be 2, 3, or 4 times as great as that of the primitive octahedron. If, on the contrary, we make a decrement of only 1 row in height, and 2, 3, or 4 in length we shall obtain octahedrons more and more obtuse, of which the elevations will be $\frac{1}{2}$, $\frac{1}{3}$, or $\frac{1}{4}$ of that of the primitive octahedron. We can therefore construct, with the same integral molecule, an indefinite series of obtuse and acute octahedrons of the same class, but which will all possess this property, that, when referred to the same base, their elevations will be to each other as the very simple numbers 1 : 2 : 3 : 4 . . . or 1 : $\frac{1}{2}$: $\frac{1}{3}$: $\frac{1}{4}$ «

(iv) *Regnault* shows that other forms result in a similar manner.

Regnault next considers a right prism, with a square base, and finally shows that a similar mode of generation is applicable to the hexagonal and even the most complex systems of crystallization.

»Starting from a point in one of its vertical edges, and symmetrically as regards this edge, let us subtract 1 row from the first stratum, 2 from the second, 3 from the third, and so on; in short, let us operate on this prism, as we did upon the cube to obtain the regular octahedron. We shall thus obtain an octahedron which will be the octahedron of the second class of the primitive octahedron, and of which the faces will have the direction of the edges of the latter. By subtracting a row in length and 2, 3, or 4 rows in height, we shall have the series of acute octahedrons of the second class. Lastly, we will obtain a series of obtuse octahedrons of the second class, by subtracting 1 row in height and 2, 3, or 4 rows in length.«

»In the entire, or holohedral forms, of the hexagonal system, we must take the regular 6-sided prism as the integral crystalline molecule. By means of this same prism, we can, by suppressing the decrements according to a certain law, construct the hemihedral forms of the same system. It is, perhaps, more easy to consider these last forms as constituted by integral molecules, hemihedral themselves, and having, for example, the form of the primitive rhombohedron. We shall merely show how scalenohedrons may be derived, in this manner, from the primitive rhombohedron having the same lateral edges. Fig. 4g represents this mode of generation of the scalenohedron (fig. 3e) of carbonate of lime: this scalenohedron has a principal axis treble of that of the primitive rhombohedron having the same lateral edges, and is frequently found in this substance. It is enough to place, on each face of the primitive rhombohedron *abcde*, strata of molecules similar in form to this rhombohedron, by effecting on its lateral edges a decrement of 2 rows in breadth and 1 row in height. The lines of separation of the elementary rhombohedrons are not seen in fig. 4g, but they are clearly exhibited in fig. 4h, which shows, on a larger scale, the upper courses of fig. 4g.«

»If we effect a decrement of 1 row in breadth and 1 in height, we should obtain a scalenohedron which, with the same secondary axes, would have a principal axis double of that of the primitive rhombohedron.

»In the fourth, fifth, and sixth systems of crystallization, the integral molecule will be a parallelepipedon, of which the elements may be determined, from those of the octahedron, chosen as the principal. At one time, the small generating solids will be the integral molecule itself; at others, they will be formed by definite aggregation of these molecules. Fig. 4i is an example of the angular decrement of one of the complex generating solids *abcdefg*. The faces thus formed, either on the edges or on the angles, will have different inclinations, which may be indefinitely varied, by varying the mode of composition of the generative solids themselves: but all these faces will present this common character, that the lengths included by them on the homologous axes will be proportional to whole numbers. This is the general law proved by observation, and to which we have already frequently referred.«

(v) The wave-theory of crystalline structure and forces illustrated by the phenomena exhibited by a grating.

The above reasoning of *Regnault* has been dwelt upon at length, because it seemed simple and well calculated to bring to light the molecular conditions and forces operative in crystalline arrangement.

There is another familiar illustration which may now be used to illuminate the effect of crystalline structure. We refer to the grating. It is to be borne in mind that crystals are productive of the most beautiful exhibitions of optical phenomena. Thus it is desirable to point out the analogy with the grating, by which classified wave arrangement is produced, according to special distribution and wave length, because this, with the molecular structure already described will explain the color phenomena in crystals.

A grating consists of a metallic surface ruled in parallel lines by means of a very fine engine, which will enable the lines to be drawn exactly parallel and on equal distance apart. The finest gratings heretofore made are those constructed by *Rowland* at Baltimore and *Michelson* at Chicago. To carry out this work with the desired accuracy *Rowland* had to produce a very perfect screw, for use in setting the diamond point for making the fine lines, from 10000 to 20000 to the inch.

The grating is thus modeled on the principle of parallel grooves, ruled by a fine point. If the metal surface were set up at the proper angle, it would present the aspect of a side of a pyramid as conceived by *Regnault*, for the theory of crystals outlined above. There is thus a close analogy between the grating and its diffraction phenomena, and the structure of a crystal.

Now in the theory of the grating we have first, second, and higher order spectra, and in each spectrum the maximum and minimum for the different wave-lengths are arranged as shown in the accompanying illustrations (fig. 5, p. 67).

1. In the upper illustration, apertures are used instead of reflection from furrows in the grating. The image formed when the lower telescope is directed normally upon the grating gives the »central image«.

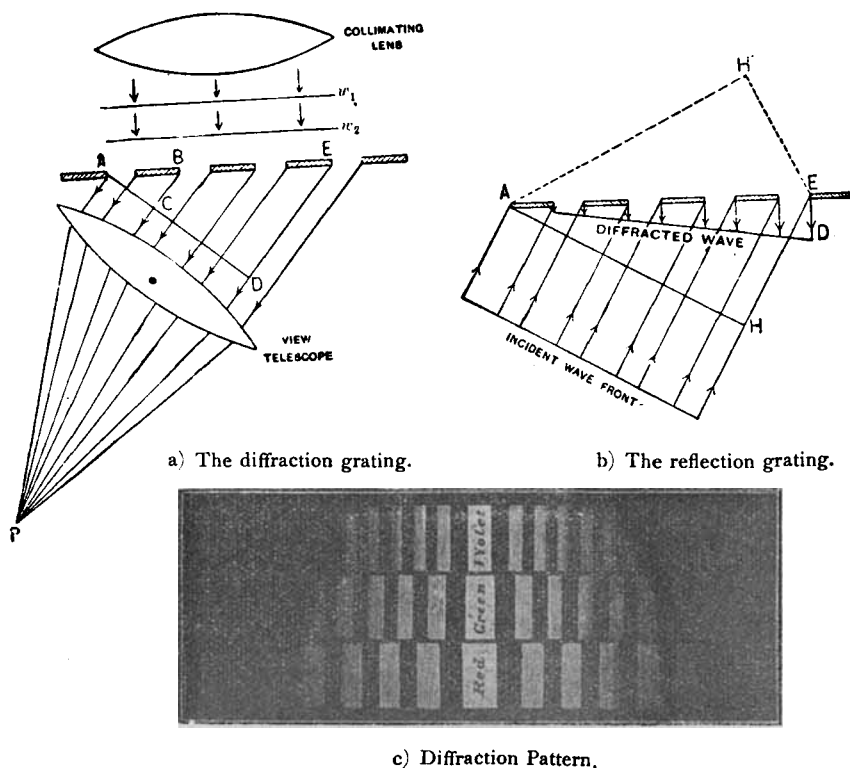

Fig. 5. Illustration of the formation of the diffraction pattern by refraction or by reflection, the wave arrangement of which presents certain analogies with crystalline structure.

2. As the telescope axis P moves to left (or to right) we encounter other secondary maxima of light. The first intense illumination on either side will occur when DE is equal to as many wave lengths as there are spaces on the grating, for then CB will be equal to one wave length, and the light from each aperture will reach the surface AD in precisely the same phase. The light concentrated at P gives the spectrum of the first order.

3. On either side, at greater angular distance from the centre, higher orders of spectra occur. The formulae are:

$$\text{For bright band } (a+d) \sin \theta = 2n \lambda/2$$

$$\text{For dark band } (a+d) \sin \theta = (2n+1) \lambda/2,$$

where $a+d$ denote the distance between the slits, a being the width of slit, and d of the bar, and n is the order of the spectrum.

4. When the light is not normal to the plane of the grating, but inclined at an angle i , we have the corresponding formulae:

$$(a+d) (\sin \theta + \sin i) = 2n \lambda/2$$

$$(a+d) (\sin \theta + \sin i) = (2n+1) \lambda/2.$$

This brief discussion shows that the phenomena of diffraction, reflection and refraction, in a crystal — where

¹ It will be noted that our theory of the hardness of diamond rests largely upon the cause of the tenacity of wire, shown to be traceable to stresses in the sheath of aether about the wire by the equation $\eta = S/V = K/r$, which indicates that the tendency to rupture the aether at the boundary must be the source of the power when the metal is drawn into wire with relatively more surface. If the cause of tenacity in drawn wire is correctly referred to boundary stress in the aether — a conclusion from which I can see no escape, in view of the results of observation agreeing with the above formula — then the cause of the hardness of diamond also follows incontestably. This conclusion is to be taken in connection with the above considerations on the wave oscillations and the resulting forces which resist compression in liquids and solids.

the molecular structure is so arranged as to make the rulings — are extremely complex. It is no wonder that a variety of optical, and physical phenomena develop, and give the crystals many wonderful properties. This necessarily results from the wave-theory.

3. The Wave-Theory explains the Hardness of Diamond and the Growth of Crystals by Accretion along Axes. The Views of Heddle and other Crystallographers cited in some detail.

(i) The extraordinary hardness of diamond due to extremely violent wave-refractions and wave-dispersions at the boundary, which tend to disrupt the medium, but thereby result in maximum powers of cohesion for the hardest of known crystalline bodies.

As we examine the problems of crystallography with some care, we first call attention to the extraordinary refraction and dispersion of light in diamond. This violent wave action tends to disrupt the medium at the boundary, but only draws around the crystal such an elastic sheath of stressed aether as to give rise to the extraordinary hardness of the diamond.

In the fifth paper, section 10, we have dealt with this question in some detail, and whilst we have not fully solved the problem, we did separate the elements on which the hardness depends, so as to lay bare the causes

at work. We have there pointed out that in the case of diamond all the light incident from two complete quadrants, or 180° , is condensed by refraction into an angular space of only $47^\circ 22' = 47.37/180 = 1/3.8$. It appears that this enormous concentration of wave energy is the secret of the most powerful molecular forces¹). For on any area of the crystal the concentration of wave energy is as the square of 3.8, or 14.44; and if the dispersive effect be about equally powerful, the combined effect of the refraction and dispersion becomes magnified 200 times.

Now the effect of such extremely violent concentrations and dispersions of wave energy is a tendency to disrupt the medium, but as this cannot be done, owing to the more rapid motion of the aetherons, $\bar{v} = \frac{1}{2}\pi \cdot V$, the result is the development about the crystal of a stressed envelope or sheath, which binds the diamond like a shell of steel. As the waves go into the diamond the movement is concentrated; as they go out an equally violent reaction, scattering, and diffusion occurs.

From a study of this stressing of the aether about the diamond, we concluded that as the aether is $\epsilon = 689321600000$ more elastic than air in proportion to its density, the tendency to the disruption of such a medium would develop forces

correspondingly larger than would arise in the air. In many physical experiments and natural phenomena, such as cyclones, the power of the air forces are impressively exhibited to our senses. These phenomena leave no doubt as to the possible concentration of power in nature.

Thus we concluded that the strength of a solid such as diamond would depend on the sextuple integral:

$$\Omega = \int_0^{\sigma/\lambda} \int_0^{\beta} \int_0^{\delta} \int_0^{\alpha} \int_0^{\rho} \int_0^{\omega} \varepsilon \cdot (\pi^2 - 1) \pi(\sigma/\lambda) \varphi(\beta) \psi(\delta) \chi(\alpha) \theta(\rho \cdot e^{-\alpha}) \varpi(\omega) d(\sigma/\lambda) d\beta d\delta d\alpha d(\rho \cdot e^{-\alpha}) d\omega \quad (7)$$

where the elements involved may be described as follows.

Fig. 6. Stresses in the aether at the boundary, owing to refraction and dispersion of waves by diamond.

1. As the waves enter they are condensed into about 1 : 14.44 of their former spherical distribution, which is equivalent to an intense contraction of the enclosed aether.
2. When the waves emerge, they undergo an equally powerful spreading out, and this expansion of the wave-front leads to a reaction in the medium also equivalent to a contraction of the envelope about the diamond.
3. Thus whether the waves enter or leave the diamond, there is violent stress in the envelope of aether at the boundary, and when the molecules have crystalline arrangement in a solid, the hardness results.

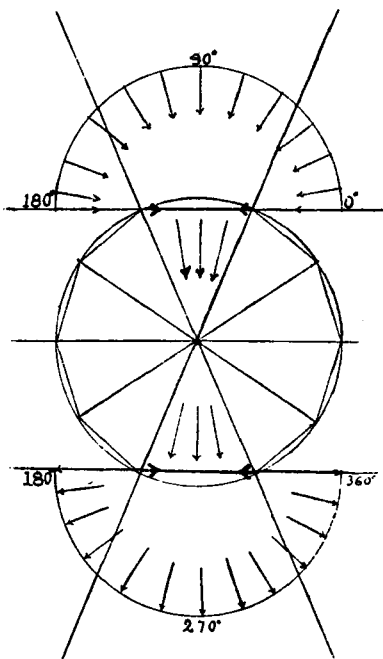

1. Refractive action, $(\pi^2 - 1)$, which depends on the density of the solid, σ , and the changing wave-length λ and thus on some unknown function, $\pi(\sigma/\lambda)$;
2. The violence of the incessant bending of the wave-front, for waves coming from all directions, $\varphi(\beta)$;
3. The violence of the incessant dispersion of these incident waves, $\psi(\delta)$;
4. The combination of systematic stresses due to the crystalline arrangement of the atomic planes with the effects of the two latter violent tendencies, thus leading almost to the disruption of the medium, $\chi(\alpha)$;
5. The enormous power of reflection with very slight absorption of energy, at the surface, $\theta(\rho \cdot e^{-\alpha})$;
6. The great central pressure due to the integration of the steady action of the sheath of partially disrupted waves always enveloping the solid, $\varpi(\omega)$.

Accordingly, although we recognize the validity of the above integral, in the present state of our knowledge, we can evaluate it only very approximately. If the other variable elements increase in about the same proportion as the energy in refraction and dispersion, which we can calculate, the result would be an increase of stress of the order of $200 \times 200 \times 200 = 8000000$ times the value otherwise effective. In view of the sudden discontinuities in the physical state of bodies, as in solidification, etc., it seems certain that the wave-theory is ample to account for the hardness of diamond and other crystals, as well as the tenacity of steel and similar substances.

In the Optics, 1721, p. 365, *Newton* pointed out that great power of adhesion is obtained when two solid plane surfaces fit with extreme closeness. In this sixth paper, our line of argument is to show that this same wave-power, based on the enormous elasticity of the aether, operates above all in chemical combinations, where the distances are ultra-microscopic in smallness.

In the case of carbon we have the small molecular weight of 12, and the element moreover crystallizing into diamond, probably under very high pressure, as in the experiments of *Moissan* and others in the production of artificial diamonds, — and thus with such smallness of molecular weight, and crystallization under conditions of the closest possible molecular contact, the resulting solid crystal ought to be the hardest of known substances.

This theory of the hardness of diamond follows at once from *Newton's* remarks, all known experience, and the resulting wave-theory of molecular and atomic forces. In our discussion, to be sure, we usually refer to the refractive index appropriate to light, but this is only for the sake of definiteness. We hold the chief atomic forces to depend on waves shorter than the ultra-violet, and thus the theoretical cohesive power is always much greater than would follow from the theory of light waves of the visual spectrum.

(ii) Views of Professor *M. F. Heddle*, on the growth of crystals by accretion along axes.

In the celebrated article on Mineralogy, *Encycl. Brit.*, 9th ed., Professor *M. F. Heddle* gives an interesting outline of the supposed mode of growth of crystals by dominant accretion along axes. *Heddle's* argument runs thus:

»As regards mere geometric measurement, there are several directions in which axes may with nearly equal advantage be projected. For example, in the cube (fig. 7 b, plate 3) they may be drawn from the centres of opposite faces, as lettered *O*; or from opposite solid angles, as lettered *C*; or from the centres of opposite edges, as lettered *D*. There is abundance of evidence that each of these directions must be regarded as lines of dominant accretion of molecules«.

»But the accretion, may be not only dominant but overwhelmingly so in one only of these directions in certain cases, or existent along one set of axes alone in certain others. In a specimen of native silver from Alva in Scotland (fig. 7 a), along *O* this is so much the case that the concreting molecules have done little more than delineate the form of an octahedron, and this they have only been able to do by aggregating themselves in lines of minute crystals of the very shape of which they were projecting the skeleton form. Moreover, a polar aggregation at the terminal ends of these octahedral axes is here shown by the amount of concreting and crystallizing material being larger at the terminations of these axes than elsewhere. In the hollow-faced cube again (fig. 7 b), an aggregation of molecules in the direction of the lines *D*

and *C* has filled the edges and solid angles, while none have been deposited along *O*. This occurs in crystals of salt. In the hollow-faced octahedron again (fig. 7c), there has been no deposition of matter along the line *C*. Cuprite often shows this form; and it as frequently occurs in hollow-faced dodecahedra, wherein the vacuity is in the direction of *D*.«

»In the specimen of pyrite from Elba (fig. 7d), a deposition along *D* and *C* would ultimately have erected the scaffolding of a hollow cube, in twelve lines of minute combinations of the cube and octahedron. Such directional arrangements may, moreover, not only be intermittent but often alternate. The pyrite from Traversella (fig. 7e) is an illustration of the first. A large pentagonal dodecahedron having been completed, a new accession of material has been attached, not uniformly spread over the pre-existent crystal, to enlarge it, but locally arranged, in equal amount, at the poles of *O*. But here the special method of the arrangement has determined the formation of a number of small crystals of the same form as that originally projected.«

»An alternation, as it were, in plan is shown in such a crystal of calcite as that in fig. 7f. Here a scalenohedron is seen in the centre of the figure; then a rhombohedron has been perched upon its summit, and lastly both have been sheathed in a six-sided prism with trihedral summits. Different as these three forms are, it is found that they all here stand in a definite position, one to the other; that definite position is the relation which they bear to one of the sets of axes, and this set may be assigned, not only to all the three crystals here combined, but also to all the crystals belonging to the same mineral, wherever occurring. This general applicability constitutes one of the respects in which one special set of axes is, in each of the systems, preferred to the others.«

(iii) Coherence of particles not equal in all directions.

Having indicated by the reasoning of *Regnault* and *Heddle* how crystals are built up by molecular arrangement, embodying various geometrical forms along certain axes, it will not surprise us to learn that the coherence of the particles is not equal in all directions. The contacts of the particles are closer in some directions than in others, and thus the forces depending on wave action yield more readily in some directions than in others. Crystals thus have planes of cleavage, and sometimes may be easily split along these planes, because the contact of the particles is not close, and the coherence of the particles not powerful.

Professor *Heddle's* discussion of this subject is as follows:

»Another respect is the intensity with which the molecules cohere in the different parts of the crystal, as referred to these axes, and the resultant different hardness of certain parts of crystals. It will be afterwards found that this obtains in a very limited manner in the crystals which belong to the first of the following systems, on account of its regularity and sameness as a whole. It may be laid down as a general rule that the edges of crystals are harder than the centres of their faces, and the solid angles harder than the edges. This is markedly the case in the diamond. But, apart from this, there is no distinctive hardness in any one part, side, or end of the crystals of the first system. It is otherwise

with the crystals which fall to be considered in all the other systems. So different is the hardness of the various portions of these, so diverse the appearance of their parts in lustre, colour, polish, etc., so varying the amount of the recoil of these when struck, so unequal their power of conducting heat, so dissimilar their power of resisting the agencies of decay, and so irreconcilable their action upon transmitted light, that we cannot but conclude that the molecules which build them up are packed with greater force, if not in greater number, in certain directions in preference to others. There thus remains no question that these nature-indicated sets of axes are those along which there has been a specially selective or 'polar' arrangement.«

(iv) In crystals, as in wire, the relative increase of surfaces gives maximum hardness.

From the above quotation it will be seen that *Heddle's* views on crystals coincide with those reached in the fifth paper on the new theory of the aether. As we had not examined *Heddle's* article when that paper was finished, we may regard the concurrence of views as remarkable. When *Heddle* says: »It may be laid down as a general rule that the edges of crystals are harder than the centres of their faces, and the solid angles harder than the edges. This is markedly the case in the diamond.« — it almost seems as if he is outlining the wave-theory as treated in the 10th section of the fifth paper.

For it will be remembered that we explained the hardness of diamond and similar bodies as due to wave action at the boundary, where there is enormous and violent refraction and dispersion, with various tendencies to disrupt the aether. And naturally these tendencies to enormous stress in the aether would be a maximum at the edges and corners of crystals, where there is minimal solid content of the crystal in proportion to its surface, so the surface effect is increased as much as possible.

We found from the study of drawn wire that the curve for the relative increase of surface, $\eta = S/V$, defined by the equation:

$$\eta = S/V = k/r \quad (8)$$

shows that the strength of wire will increase with the decrease of the radius of the wire r , so long as the diameter of the wire is not made so small as to approach the diameters of the molecules. From this law of the asymptotic increase of strength, with decreasing r , we justly inferred that wave action at the boundary of the wire must be the secret of the strength of drawn wire.

Now likewise for crystals, in the above general rule, *Heddle* lays it down that the edges and corners offer maximum hardness — evidently because the surface effect is there a maximum.

Hence we have the following remarkable induction relative to laws of nature not heretofore suspected.

1. Wire attains maximum strength or tenacity when so drawn as to make the ratio of the surface to the volume a maximum, as long as molecular dimensions are not approached.

2. Crystals likewise present maximum hardness at edges and corners, where the ratio of the amount of surface to volume is a maximum — just as in the case of drawn wire.

T. J. J. See. New Theory of the Aether.

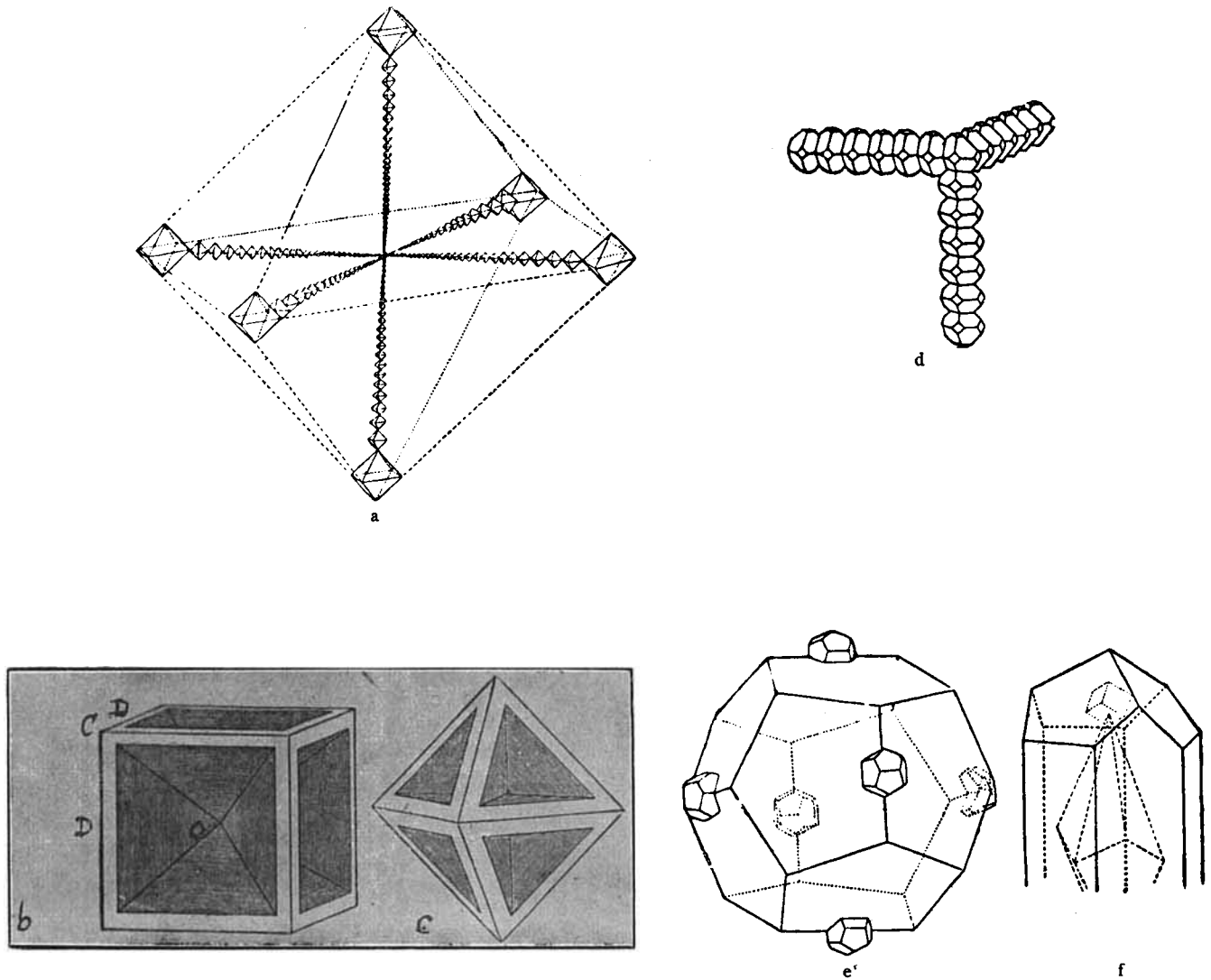
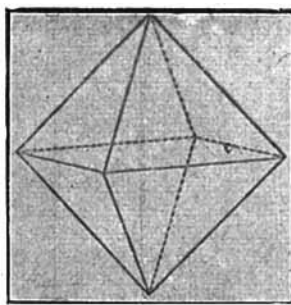
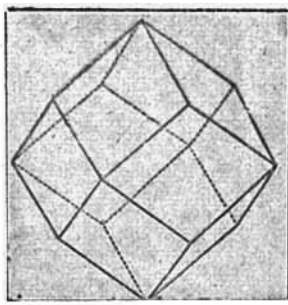

Fig. 7. Construction of crystals by the geometrical arrangement of small elements as described by *Hedde*.

T. J. J. See. New Theory of the Aether.



a. The Octahedron.



b. Rhombic Dodecahedron.

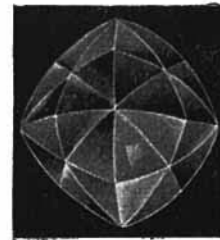

Natural Crystal.

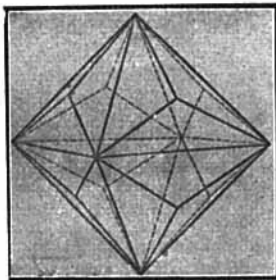

c. Triakis octahedron.

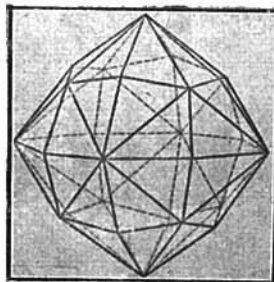

d. Hexakis octahedron.

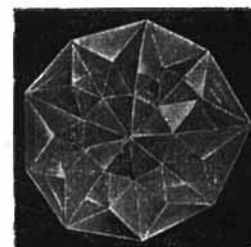

Florentine Crystal.

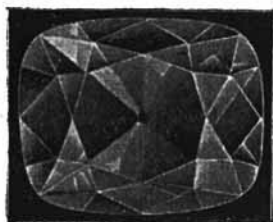

Star of the South.

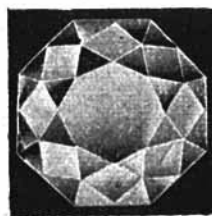

The Pasha of Egypt.

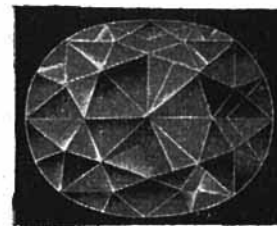

The Kohinur.



The Regent or Pitt.

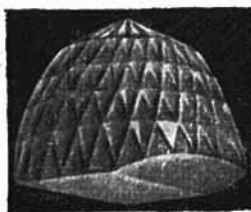

The Orloff.



The Great Mogul.

Fig. 8. The geometrical forms taken by diamond crystals, with illustrations of the most celebrated diamonds.

If therefore wave action at the boundary will explain the tenacity of wire, it will also explain the hardness of crystals. Any other conclusion seems wholly excluded. Thus the observed properties of crystals confirm the wave-theory of physical forces.

(v) Study of the crystallization of the diamond, which most strikingly confirms the wave-theory.

Investigation shows that diamond always occurs in crystals belonging to the tesseral or cubical system, usually in the octahedron, or double four-sided pyramid (fig. 8a, plate 4), the rhombic dodecahedron, with twelve faces (fig. 8b); the triakis-octahedron, 3-sided pyramids superposed on the octahedron form (fig. 8c); or hexakis-octahedron, 6-sided pyramids superposed on the octahedron form (fig. 8d).

The crystallography of the diamond is thus remarkable for the symmetry and compactness of the forms taken. Indeed it is noted that the faces of these symmetrical crystals often are curved, and many of the crystals thus become so round as to be almost like spheres, which we may readily understand from the above figures 8b and d.

Now it is remarkable that carbon as an element has extraordinary properties, as follows:

1. In the case of elements other than carbon the number of atoms directly associated together in a molecule of the compounds is very small, probably seldom or never exceeding five.

2. Carbon compounds on the other hand frequently contain a relatively very large number of carbon atoms; and from the behavior of these compounds, it is inferred that the included carbon atoms are in direct association with each other.

3. Whilst none of the remaining elements are known to furnish more than a single stable compound with hydrogen, the number of stable compounds of carbon with hydrogen found by chemists is counted by the hundreds.

4. Wherefore it is concluded that carbon has two distinctive properties: first, that of uniting with itself to an almost unlimited extent, in comparison with other elements; second, that of combining with hydrogen in numerous proportions.

5. Carbon is thus capable of uniting with the same element in a multiplicity of proportions, thereby furnishing a great variety of compounds, which probably exceed in number those of all the remaining elements taken together. Carbon is thus the whole basis of organic chemistry!

6. In view of these remarkable chemical properties it will now be obvious why crystals of carbon take the form nearest approaching that of the sphere. The chemical affinity acts with great equality from all directions, and builds up crystals of the tesseral form, often with curved faces, resembling a sphere.

It is found that the cleavage of diamond is parallel to the face of such crystals as the octahedron: which shows that the hardness of coherence of the atoms is least in the direction normal to the face of the crystal. In this respect diamond is a typical crystal, rather brittle, but the hardest of all known substances.

The high refractive and dispersive power of the diamond has already been dealt with in the 10th section of the fifth

paper. These properties were known over two centuries ago, and Sir *Isaac Newton* himself conjectured that diamond is a substance of peculiar nature. Sir *David Brewster's* discovery that many diamonds show traces of double refraction may be explained by the extreme internal pressure or stress due to the wave action at the boundary, which gives the diamond such extraordinary hardness.

The numerous internal reflections of the light, total when the angle is above $23^{\circ} 41'$, makes the diamond extraordinarily brilliant, and fills the crystal with maximum dispersion of prismatic light, whence the value of the crystal as a gem.

In view of modern studies on radio-activity, it is remarkable that as early as 1664 *Robert Boyle* noticed that when exposed to the light of the sun diamond has the property of shining in the dark, or phosphorescing. This was before the combustibility of diamond was established by the Florentine academicians, 1694-5, by means of a series of experiments with a powerful burning glass, in the presence of *Cosmo III*, Grand Duke of Tuscany. *Lavoisier* found by similar experiments that the chemical product of the combustion was carbon dioxide, CO_2 .

4. The Development of Heat in Chemical Reactions a Proof of the Wave-Theory.

(i) Heat applied to certain mixed atoms will frequently bring about their union: but greater heat leads to instability.

It has long been noticed that when atoms are combining to form new substances, heat is the immediate product of chemical affinity. The invariable rule is that in chemical combination heat is produced. Some half a century ago *Berthelot* devoted great attention to the determination of the heat developed in various combinations, thereby developing thermo-chemistry into an important special branch of that great science.

Berthelot's researches should be studied in his *Essai de mécanique chimique fondée sur la thermo-chimie*, Paris, 1879. The formulæ for the energy given up in chemical changes may be written

$$\sum T_0 = \sum (1/2 m v_0^2 - 1/2 m v^2) \quad (9)$$

where v is the velocity attained and v_0 the original velocity.

Here $\sum T_0$ is the work done while the system passes from the first to the second state. If $\sum T_1$ is the work done or energy given up in another transformation, we should have

$$\sum T_1 = \sum (1/2 m v_1^2 - 1/2 m v^2) \quad (10)$$

and therefore for the difference we get

$$\sum 1/2 m v_1^2 - \sum 1/2 m v_0^2 = \sum T_1 - \sum T_0 \quad (11)$$

Accordingly, for any state whatever, we have for a system subjected to no exterior cause, independent of its actual coordinates

$$\sum 1/2 m v_1^2 - \sum T_1 = \sum 1/2 m v_0^2 - \sum T_0 = C \quad (12)$$

where C is the constant quantity which *Rankine* calls the energy of the system.

The general equation of dynamics was given by *Lagrange* in the usual rectangular coordinates:

$$\sum [(X - m \cdot d^2x/dt^2) \delta x + (Y - m \cdot d^2y/dt^2) \delta y + (Z - m \cdot d^2z/dt^2) \delta z] = 0 \quad (13)$$

or in the more common form

$$\sum m(d^2x/dt^2 \cdot \delta x + d^2y/dt^2 \cdot \delta y + d^2z/dt^2 \cdot \delta z) = \sum (X \delta x + Y \delta y + Z \delta z). \quad (14)$$

Now the left member of this equation yields:

$$\begin{aligned} & \sum m(d^2x/dt^2 \cdot \delta x + d^2y/dt^2 \cdot \delta y + d^2z/dt^2 \cdot \delta z) = \\ & = (d/dt) \sum m(dx/dt \cdot \delta x + dy/dt \cdot \delta y + dz/dt \cdot \delta z) - \delta \left\{ \frac{1}{2} \sum m [(dx/dt)^2 + (dy/dt)^2 + (dz/dt)^2] \right\}. \end{aligned} \quad (15)$$

When we put $T = \frac{1}{2} \sum m [(dx/dt)^2 + (dy/dt)^2 + (dz/dt)^2] = \frac{1}{2} m v^2$ and $U' = \sum (X \delta x + Y \delta y + Z \delta z)$ (16)

we get from (14) $(d/dt) \sum m(dx/dt \cdot \delta x + dy/dt \cdot \delta y + dz/dt \cdot \delta z) = \delta T + U'$ (17)

whence we derive *Hamilton's* principle for a conservative system:

$$\int_{t_0}^{t_1} (\delta T + U') = 0 \quad (18)$$

But molecular and atomic systems undergoing change are not conservative, since invariably there is development of heat due to chemical combination. Parts of the system pass from the free state to the bound state, and in the rapid adjustment of the velocities of the molecules and atoms, there is such rearrangement of their moving wave-fields, that heat is developed. The work done thus naturally has largely the form of aether waves, which tend to diffuse the heat of combination.

Accordingly, in chemical systems the principle of *Hamilton* will not hold, and equation (18) takes the form:

$$\int_{t_0}^{t_1} (\delta T + U') = \Theta \quad (19)$$

where Θ is the number of heat units developed or absorbed by the chemical combinations taking place in the system during the interval $t_1 - t_0$.

If the change of temperature be immense and violent, as by the application of external heat, molecular structures, stable at lower temperature, may become unstable and the combinations break up, because the agitation due to the longer waves predominate over the shorter waves on which chemical affinity mainly depends. This fact confirms the wave-theory.

The following tables include some of the principal results found by the researches of *Berthelot*, *Thomsen* and others. The first table gives the amounts of heat developed on the addition of sodium hydroxide (2 NaOH Aq, Q Aq).

Name of Acid	Formula	Units of heat developed in the reaction (2 NaOH Aq, Q Aq)
Hydrofluoric	2 H·Fl	32540
Sulphuric	H ₂ ·SO ₄	31380
Selenic	H ₂ ·SeO ₄	30390
Hypophosphorous	2 (H·PH ₂ O ₂)	30320
Sulphurous	H ₂ SO ₃	28970
Metaphosphoric	2 (H·PO ₃)	28750
Phosphorous	H ₂ ·PHO ₃	28370
Oxalic	H ₂ ·C ₂ O ₄	28280
Hydrochloric	2 H·Cl	27480
Hydrobromic	2 H·Br	27500
Hydriodic	2 H·I	27350
Chloric	2 H·ClO ₃	27520
Nitric	2 H·NO ₃	27360

Name of Acid	Formula	Units of heat developed in the reaction (2 NaOH Aq, Q Aq)
Dithionic	H ₂ ·S ₂ O ₆	27070
Selenious	H ₂ ·SeO ₃	27020
Chloroplatinic	H ₂ ·PtCl ₆	27220
Fluosilicic	H ₂ ·SiF ₆	26620
Sulphovinic	2 (H·SO ₄ C ₂ H ₅)	26930
Formic	2 (H·CHO ₂)	26400
Acetic	2 (H·C ₂ H ₃ O ₂)	26310
Pyrophosphoric	$\frac{1}{2}$ (H ₄ ·P ₂ O ₇)	26370
Phosphoric	H ₂ ·PO ₄ H	27080
Arsenic	H ₂ ·AsO ₄ H	27580
Citric	$\frac{2}{3}$ (H ₃ ·C ₆ H ₅ O ₇)	25470
Tartaric	H ₂ ·C ₄ H ₄ O ₆	25310
Succinic	H ₂ ·C ₄ H ₄ O ₄	24160
Chromic	H ₂ ·CrO ₄	24720
Carbonic	H ₂ ·CO ₃	20180
Boric	H ₂ ·B ₂ O ₄	20010
Hypochlorous	2 (H·OCl)	19370
Hydrosulphuric	2 (H·SH)	15480
Hydrocyanic	2 (H·CN)	5530
Stannic	$\frac{1}{2}$ (H ₄ ·SnO ₄)	4780
Sillicic	$\frac{1}{2}$ (H ₄ ·SiO ₄)	2710

This table is from the article *Chemistry*, *Encycl. Brit.*, 9th ed. The explanation of the table by Professor *H. E. Armstrong* is of interest:

»From these tables it will be evident — (1), that when a molecule of sodium hydroxide in aqueous solution enters into reaction with an acid, the heat developed is very nearly proportional to the quantity of acid present until this amounts to 1, $\frac{1}{2}$, $\frac{1}{3}$, or $\frac{1}{4}$ molecule, according as the acid is mono-, di-, tri-, or tetrabasic; but that when the amount of acid added exceeds that requisite to form the normal salt, the different acids behave differently, heat being in some cases developed, and in others absorbed, according to the constitution of the acid; and (2), that mostly when a molecule of an acid in aqueous solution enters into reaction with sodium hydroxide, the amount of heat developed increases almost in proportion to the amount of the latter, and until 1, 2, 3, or 4 molecules are added, according as the acid is mono-, di-, tri-, or tetrabasic; the further addition of sodium hydroxide is not then attended with any considerable development of heat.«

»Very different amounts of heat, it will be observed, are developed on neutralizing the different acids, but there is mostly a remarkable similarity in the results obtained in the case of acids which from chemical evidence are known to be closely allied.«

Professor *Armstrong* then adds a more detailed discussion, which for lack of space we are obliged to omit, proving the general theory here outlined. Several other tables are cited by Professor *Armstrong*, those derived from the chemical investigations of *Thomsen* of Copenhagen being highly important; but the results are too elaborate to be cited here.

The related chemical problem of the number of units of heat developed or absorbed per molecule when salts are dissolved in water could be discussed with profit. And we might go into the problem of atomic heat, with average value of about 6.3; but it involves too much chemical detail for a discussion of the cause underlying physical forces.

It must suffice to point out that the heat developed or absorbed is proof positive of the vast stores of energy drawn upon in the combinations of matter into molecular bodies familiar to chemists. Free or temporarily free atoms are combined into molecules of greater or less stability; and in the commotion incident to the change of state, energy is set free, mainly in the form of heat.

It would be possible to imagine that the energy comes from within the atoms themselves; but such a view has great improbability for three reasons:

1. We cannot conceive how the energy can be stored in the atoms, since it is characteristic of energy to expend itself with very great rapidity.

2. There is no apparent reason why different atoms should have such different energy, in respect to other atoms or molecules, if energy be inherent in matter.

3. This theory would place all the energy in the common matter and leave none in the aether, — which is infinitely improbable, since the aether is perfectly elastic and thus the vehicle of all energy. Therefore it is improbable, almost inconceivable, that energy can really reside in matter as such.

Accordingly, we reach the conclusion that so far from residing in matter, the energy resides in the aether itself, but only exhibits its power in connection with matter, because matter operates to transform the waves, owing to sudden changes of movement at the boundaries. Hence the main function of matter is the transformation of wave energy; and naturally the effects are different with different substances. No other theory will explain the chemical energies evolved in combinations which often are so extremely powerful.

(ii) Heat developed by chemical affinity attributed to transformation of molecular and atomic motion, but when the liberated energy is confined, and new gases formed in the disturbance of the system, their expansive power may give motion to projectiles.

The main distinction between chemical affinity and the physical attraction seen in molecular forces, consists in the fact that the action of chemical affinity is accompanied by chemical changes, whereas purely molecular forces do not change the internal structure of the molecules. Agitation of the molecules generates heat, by the rearrangement of the surrounding wave-field, and when the parts of molecules or atoms are violently agitated and reconnected, as in chemical changes, it is natural that heat should be evolved. This rearrangement of the parts of the molecule, with dissociation and regrouping of atoms, under the wave energies of the universe, thus leads to heat, and lies at the foundation of thermo-

chemistry as developed by *Berthelot*, *Thomsen*, and other modern investigators.

In discussing chemical changes, *W. R. Grove* (Correlation and conservation of forces, p. 153) says:

»It may be a question whether in this case, the force which occasions the motion of the mass is a conversion of the force of chemical affinity, or whether it is not, rather, a liberation of other forces existing in a state of static equilibrium, and having been brought into such state by previous chemical actions; but, at all events, through the medium of electricity chemical affinity may be directly and quantitatively converted into the other modes of force. By chemical affinity, then, we can directly produce electricity; this latter force was, indeed, said by *Davy* to be chemical affinity acting on masses: it appears rather to be chemical affinity acting in a definite direction through a chain of particles; but by no definition can the exact relation of chemical affinity and electricity be expressed; for the latter, however closely related to the former, yet exists where the former does not, as in metallic wire, which when electrified, or conducting electricity, is nevertheless, not chemically altered, or, at least, not known to be chemically altered.«

»*Volta*, the antitype of *Prometheus*, first enabled us definitely to relate the forces of chemistry and electricity. When two dissimilar metals in contact are immersed in a liquid belonging to a certain class, and capable of acting chemically on one of them what is termed a voltaic circuit is formed, and, by the chemical action, that peculiar mode of force called an electric current is generated, which circulates from metal to metal, across the liquid, and through the points of contact.«

»Let us take, as an instance of the conversion of chemical force into electrical, the following, which I made known some years ago. If gold be immersed in hydrochloric acid, no chemical action takes place. If gold be immersed in nitric acid, no chemical action takes place; but mix the two acids, and the immersed gold is chemically attacked and dissolved: this is an ordinary chemical action, the result of a double chemical affinity. In hydrochloric acid, which is composed of chlorine and hydrogen, the affinity of chlorine for gold being less than its affinity for hydrogen no change takes place; but when the nitric acid is added, this latter containing a great quantity of oxygen in a state of feeble combination, the affinity of oxygen for hydrogen opposes that of hydrogen for chlorine, and then the affinity of the latter for gold is enabled to act, the gold combines with the chlorine, and chloride of gold remains in solution in the liquid. Now, in order to exhibit this chemical force in the form of electrical force, instead of mixing the liquids, place them in separate vessels or compartments, but so that they may be in contact, which may be effected by having a porous material, such as unglazed porcelain, amianthus, etc., between them. Immerse in each of these liquids a strip or wire of gold: as long as these pieces of gold remain separated, no chemical or electrical effect takes place; but the instant they are brought into metallic contact, either immediately or by connecting each with the same metallic wire, chemical action takes place — the gold in the hydrochloric acid is dissolved, electrical action also takes place, the nitric acid is deoxidised by the transferred hydrogen, and a current

of electricity may be detected in the metals or connecting metal by the application of a galvanometer or any instrument appropriate for detecting such effect.«

»There are few, if any, chemical actions which cannot be experimentally made to produce electricity: the oxidation of metals, the burning of combustibles, the combination of oxygen and hydrogen etc., may all be made sources of electricity. The common mode in which the electricity of the voltaic battery is generated is by the chemical action of water upon zinc; this action is increased by adding certain acids to the water, which enable it to act more powerfully upon the zinc, or in some cases act themselves upon it; and one of the most powerful chemical actions known, — that of nitric acid upon oxidable metals — is that which produces the most powerful voltaic battery, a combination which I made known in the year 1839; indeed, we may safely say, that when the chemical force is utilised, or not wasted, but all converted into electrical force, the more powerful the chemical action, the more powerful is the electrical action which results.«

Again, in describing the voltaic battery, *Grove* says:

»Now a voltaic battery, which consists usually of alternations of two metals, and a liquid capable of acting chemically upon one of them, has, as we have seen, the power of producing chemical action in a liquid connected with it by metals upon which this liquid is incapable of acting; in such case the constituents of the liquid will be eliminated at the surfaces of the immersed metals, and at a distance one from the other. For example, if the two platinum terminals of a voltaic battery be immersed in water, oxygen will be evolved at one and hydrogen at the other terminal, exactly in the proportions in which they form water; while, to the most minute examination, no action is perceptible in the stratum of liquid. It was known before *Faraday's* time that, while this chemical action was going on in the subjected liquid, a chemical action was going on in the cells of the voltaic battery; but it was scarcely if at all known that the amount of chemical action in the one bore a constant relation to the amount of action in the other. *Faraday* proved that it bore a direct equivalent relation: that is, supposing the battery to be formed of zinc, platinum, and water, the amount of oxygen which united with the zinc in each cell of the battery was exactly equal to the amount evolved at the one platinum terminal, while the hydrogen evolved from each platinum plate of the battery was equal to the hydrogen evolved from the other platinum terminal.«

»Supposing the battery to be charged with hydrochloric acid, instead of water, while the terminals are separated by water, then for every 36 parts by weight of chlorine which united with each plate of zinc, eight parts of oxygen would be evolved from one of the platinum terminals: that is, the weights would be precisely in the same relation which *Dalton* proved to exist in their chemical combining weights. This may be extended to all liquids capable of being decomposed by the voltaic force, thence called electrolytes: and as no voltaic effect is produced by liquids incapable of being thus decomposed, it follows that voltaic action is chemical action taking place at a distance, or transferred through a chain of media, and that the chemical equivalent numbers are the exponents of the amount of voltaic action for corresponding chemical substances.«

»As heat, light, magnetism, or motion, can be produced by the requisite application of the electric current, and as this is definitely produced by chemical action, we get these forces very definitely, though not immediately, produced by chemical action.«

(iii) *Adolphe Wurtz's* theory of chemical affinity.

In his well known History of chemical theory, from the age of *Lavoisier* to the present time, (1869), the celebrated French chemist *Adolphe Wurtz* reached the conclusion that chemical phenomena depend for their cause on the diversity of matter. As stated in the work above cited (translation by *Watts*, London, 1869) pp. 193-194, *Wurtz's* theory is as follows:

»We have seen the progress of ideas following closely on the march of discovery, and arriving, through many variations, at the same fundamental idea, that, namely which consists in seeking the first cause of chemical phenomena in the diversity of matter, each primordial substance being formed of atoms endowed with a certain energy, and with a peculiar aptitude for expending that energy. These two properties of atoms, distinct from one another, render an account of all chemical phenomena, the former measuring their intensity, the latter denoting their manner. Affinity and atomicity are, therefore, the two manifestations of the force which resides in the atoms, and this hypothesis of atoms forms at present the foundation of all our theories, the solid base of our system of chemical knowledge. It gives a striking simplicity to the laws relating to the composition of bodies; it enables us to look into their intimate structure; it intervenes in the interpretation of their properties, reactions, and transformations; and will doubtless at some future time furnish points of support for the science of molecular mechanics.«

»It was, therefore, a grand idea that was originated by *Dalton*, and it may with good reason be asserted, that amongst all the advances that chemical doctrines have made, since the time of *Lavoisier*, this is the most important.«

It thus appears that *Wurtz* attributed all chemical manifestations of force to affinity and atomicity, and held that the support for a science of molecular mechanics must be based thereon. He considered every primordial substance to be »formed of atoms endowed with a certain energy, and with a peculiar aptitude for expending that energy«.

The wave-theory differs from *Wurtz's* view chiefly in attributing all energy to the aether, while the atoms receive, transform, and emit wave energy suitable to their atomic properties and periodicities. This is a simpler conception than *Wurtz's* and it gives to the atoms the properties of resonators, — all energy being inherent in the aether itself, which has an elasticity 689321600000 greater than that of air in proportion to its density.

The phenomena of radio-activity and the kindred phenomena of phosphorescence enable us to see that the wave-theory offers the simplest and most general explanation of radiation, whatever be its form. In 1664, *Boyle* observed that a diamond glows in the dark after having been exposed to the direct action of sunlight. This was probably the earliest observation of the persistence of luminous vibrations after the exciting cause was removed. If the carbon atoms crystallized in diamond may persist in their vibrations it is after all not

such a long step to radio-activity, where the radiation continues almost indefinitely. Thus radium differs from diamond chiefly in the much greater duration of the radiation emitted and the violence of the waves given out. But carbon has an atomic weight of only 12, while radium has an atomic weight of 205, over 17 times greater.

As bearing upon world-radio-active phenomena, we may cite the Aurora Borealis, which occasionally adds to the luminosity of our atmosphere by waves emitted from sunspots, and so transformed in the earth's atmosphere as to give light. On May 14, 1921, we witnessed at Mare Island the most brilliant aurora ever noted in California.¹⁾ At 9^h 30^m p. m., Pacific Standard Time, the auroral streamers extended from the northern horizon to the zenith and beyond; the colors displayed included red, orange, yellow, green, and bluish purple. The streamers showed rapid formation and dissolution, and at about 10 o'clock a canopy of light, like that often reported in Norway and Lapland, formed near the zenith, sixty degrees wide. It afterwards scattered, and appeared as luminous clouds in many parts of the sky.

For many years the aurora has been known to be periodic, and to follow the curve of the sun-spot development. As an unusually large spot was near the central meridian of the sun, this display verifies the electromagnetic wave-theory published by the writer in 1917, and further verified in a paper communicated to the Astronomical Society of France in November, 1918.

From researches covering a very wide field it seems absolutely certain that electrical forces control the physical world, and that both magnetism and gravitation are wave-phenomena, depending on stresses in the aether, a new mathematical-physical theory of which we have developed during the past seven years.

5. The Geometric Basis of the Atomic Arrangement in the Wave-Theory of Molecular Structure also points to the Source of Power in High Explosives.

(i) The resistance of a given molecular structure to passing waves depends upon the atomic arrangement. It may vary between forms which yield maximum to minimum resistance.

In our wave-theory of the hardness and tenacity of bodies, in the fifth paper on the new theory of the aether, we found overwhelming evidence that these properties of bodies, by which they have enormous physical strength, depend on wave transformations and the resulting stresses in the aether at the boundaries of these bodies. Boundary conditions are all-important in fixing the physical properties of gross bodies, because the transformation of waves with the resulting stresses in the aether occur at the boundaries.

Now just as the boundary transformations of waves may generate enormous stresses about and throughout a large body made up of an infinite number of atoms, so also this boundary condition, when reduced to the problem of geometrical figures, may give molecules and atoms properties of greater or less strength and stability.

¹⁾ This section slightly rewritten on May 16.

In fact there is no doubt that there is in general one arrangement which will give minimum stability and another will give maximum stability of the atomic arrangement. It is upon this strength that the stability of the structure of the molecule depends.

In the case of diamond, we have noted that the tendency is to form crystals as nearly spherical as possible; and we have pointed out the probability that the hardness of diamond depends upon the indefinite possibility of combinations of carbon with carbon, just as the multitudinous combinations of carbon with hydrogen give rise to the immense groups of hydrocarbons, and thus form the principal basis of organic chemistry. On this point, dealing with the properties of carbon, we quote the impression of the eminent French chemist *Adolphe Wurtz*, (*History of chemical theory*, 1869, pp. 159-160):

»Why, indeed, do the atoms of carbon exhibit this singular tendency to accumulate in large numbers in organic molecules? Because they possess the property of combining together, of riveting themselves one to the other. This important property gives to the innumerable compounds of carbon a peculiar stamp, and to organic chemistry its physiognomy, its mode of being. No other element possesses this power in the same degree. Doubtless hydrogen can combine with itself, as recognized by *Gerhardt*; but, as an atom of this body exhausts its combining capacity by its union with a second atom, no other element can be added to this couple, the saturated molecule of which is reduced, as it were, to its simplest expression, being formed of two atoms.«

»The polyatomic elements alone, after having expended part of the combining capacity which resides in them in riveting themselves one to the other, can retain another part to fix other elements. This power is possessed by the atoms of carbon, and likewise by the atoms of oxygen.«

It appears that the geometrical mechanism underlying molecular and atomic forces is somewhat obscure, yet there can be no doubt that different arrangement of the component part may be made so as to give greatly different degrees of compactness and therefore of stability. The subject of the geometrical figures and their possible combinations has been treated of by many authors, beginning with *Kepler's* *Mysterium Cosmographicum*, 1596. Among recent works we shall only allude to two:

1. Growth and Form, by *D'Arcy W. Thompson*, Cambridge University Press, 1917.

2. Fundamentals of the Cosmos, by Colonel *John Millis*, U.S.A., 1918, (*Science*, Oct. 11, 1918).

The work by *Thompson* has reference to the development of organic bodies, and thus is of interest in biology. The work by *Millis* is of wider application, and involves »a simple geometrical principle and its possible significance in connection with general physical theory.«

The principle stated by *Millis* is that: »In any aggregation of an indefinite number of equal spherical bodies an arrangement giving minimum total volume occupied and perfect symmetry throughout is impossible«. *Millis* recognizes that in every case there is an arrangement giving maximum

T. J. J. See. New Theory of the Aether.

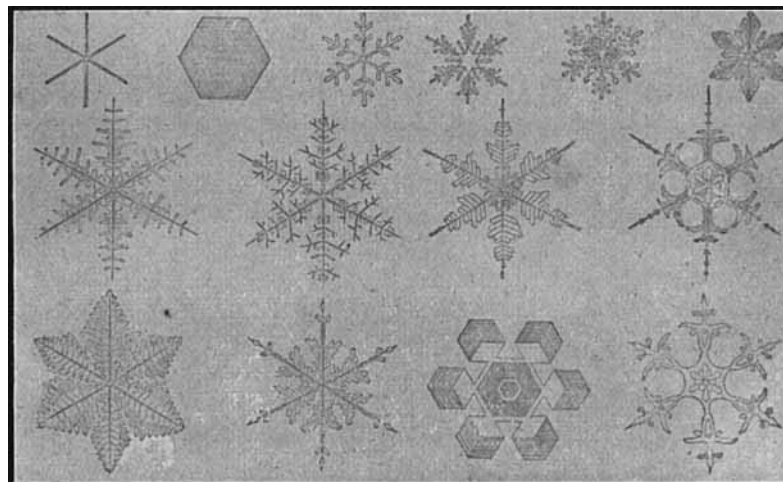
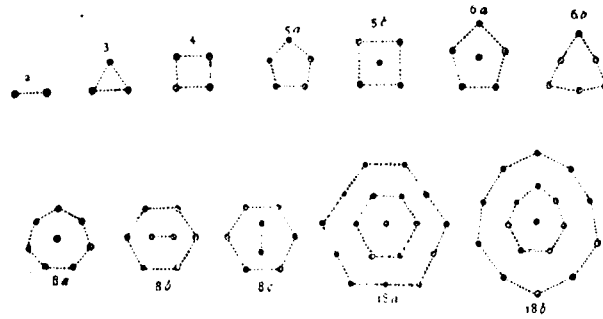

Fig. 10. 1. *Mayer's* stable forms of groups of floating magnets.
 2. Geometrical forms taken by crystals of snow.

T. J. J. See. New Theory of the Aether.

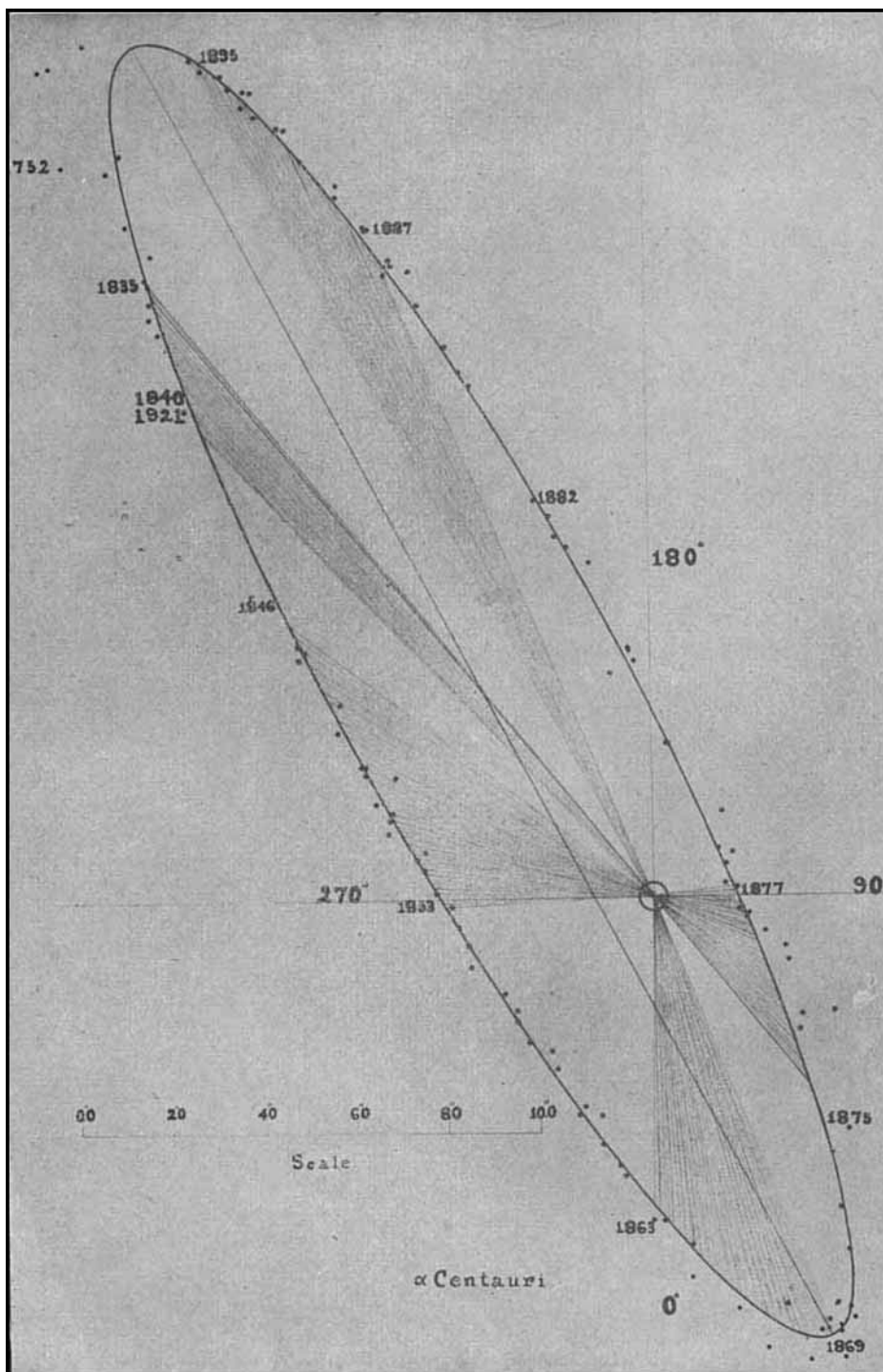

Fig. 11. The apparent orbit of Alpha Centauri, with extremely variable radius vector, yet under the central force of universal gravitation sweeping over equal areas in equal times. (From *Researches on the evolution of the stellar systems*, vol. I, 1896.)

C. Schaidt, Inhaber Georg Oheim, Kiel.

T. J. I. See. New Theory of the Aether.

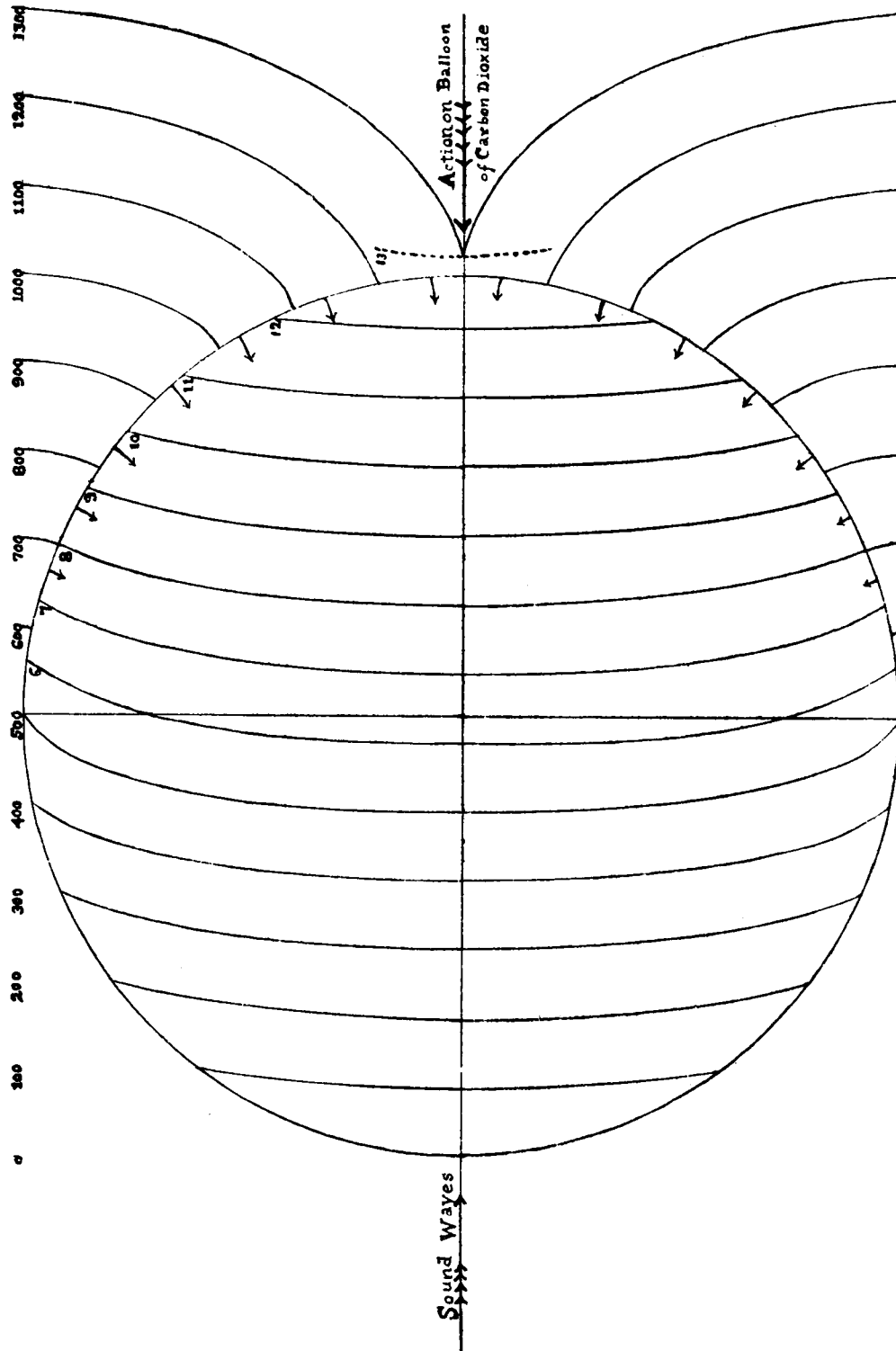

Fig. 12. Graphical illustration of the progress of the wave-front, in the case of sound, propagated through the air and through the carbon dioxide (CO_2) of the balloon. This gives acoustic attraction, owing to the advance wave-motion working some of the air particles out from between the source of the sound and the balloon, and transferring them beyond the balloon, so as to give a vis a tergo, a shove from behind.

condensation and geometrical symmetry, yet the density with the spheres in contact is not a maximum. He summarizes his conclusions thus:

»The only possible arrangement or grouping of equal spheres in contact that gives perfect symmetry as a fixed condition throughout for a group of an indefinite number is the cubical system, and this does not give maximum density; while the only possible arrangement that gives maximum density as a fixed condition throughout such a group is the rhombic dodecahedral, but this does not give universal symmetry. There is no arrangement possible giving both maximum density and universal symmetry.«

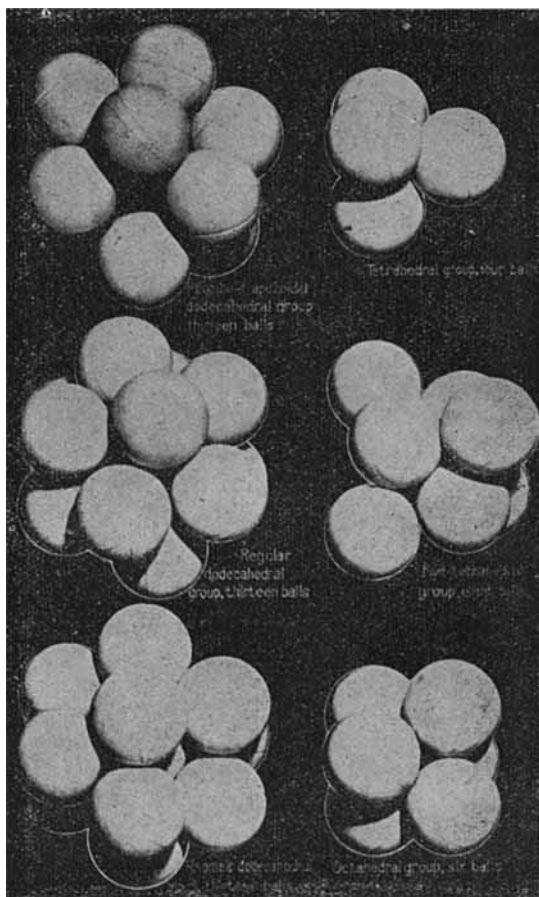

Fig. 9. Forms of arrangement for compact spheres in contact, (Millis).

There are other suggestions regarding symmetry and arrangement of forms for spheres or particles of bodies, but we shall not go into them beyond the suggestions conveyed by the illustrations (Fig. 9.) from the paper of Colonel *Millis*.

(ii) The atoms are separated in the molecules like the parts of *Mayer's* floating magnets.

It now remains to point out that in the wave-theory the groupings above represented, and an infinity of other groupings, are possible for the atoms, but the atoms making up the molecule are to be conceived as separated by relatively large

spaces, as in the stable geometrical figures found by *Mayer* for groups of floating magnets.

These floating magnets are illustrated in the figure 10, plate 5, which probably convey to us as good an outline of the molecules or atoms as any known models.

The chief difference we suggest in the model molecule is that in nature we do not have magnets surrounded by polarized groups of waves, but waves filling the universe, and affecting the atoms from every direction, so that the molecule is the symmetrical arrangement of least resistance to the passing waves.

This involves a different cause for the forces known to be at work, but the geometrical forms which result will be very similar; and under certain conditions of temperature or wave agitation the forms are stable. Yet under other conditions there is a rupture of the stability, and the molecule breaks up, with inevitable rearrangement of the atoms or parts, which in their mutual relations may be compared to the parts of *Mayer's* floating magnets.

The picture here given is the simplest and most direct outline of the wave-theory of molecular and atomic structure. When the number of atoms is large a good many geometrical forms may be assumed; but, with diverse properties to the atoms, the combinations frequently are unstable, or stable only within narrow limits, as in the above model floating magnets devised by *Mayer*.

The symmetry of these magnets and their analogy with cross sections of crystals is too obvious to escape the notice of the sagacious observer. In fact *Mayer's* magnets 18a and 18b strikingly resemble the form of crystallization taken by diamond, the purest form of carbon, where the molecular and atomic forces, due to wave-action have unrestricted freedom of operation in arranging the parts to give the best symmetry and maximum hardness.

In contemplating the above figures of *Mayer's* floating magnets, we should remember that all the elements are in one plane — the level surface of the water, — which we may call *xy*. But in the theory of atomic and molecular structure we have to view the atoms or parts of the molecule as lying in tridimensional space, *xyz*. Thus many more geometrical forms are possible for atoms in the structure of the molecule than is shown above in *Mayer's* figures.

(iii) Instability of the geometrical arrangement in molecular structure may lead to rearrangement, under disturbance, and thus the mystery of explosive forces finds explanation in the release of energy due to the elastic power of the aether.

From the theory of molecular and atomic structure here outlined, it follows that very different degrees of stability should exist. In general molecular structure is broken up by excessive heat, because under the agitation of the heat waves, which are of greater length, the atoms are likely to be driven beyond the range of action of the atomic forces due to the shorter waves. Thus heat or electric current may lead to dissociation, and the separation of the elements, as in Sir *Humphrey Davy's* celebrated experiments on the alkaline earths, about 1807.

Now just as heat and the electric current may produce dissociation, by driving the constituent atoms beyond the range of action of the atomic forces, so also when the form of

atomic arrangement is not very stable, a quick disturbance may so derange the geometric figure as to cause molecular collapse of the existing structure of the atoms, and rearrangement into other figures, usually more but sometimes less stable.

This gives us a clue to the secret of explosive forces, which heretofore has challenged the ingenuity of natural philosophers.

If we consider the great body of high explosives, we recall the well known fact that many of them are highly unstable, and will not bear any violent shock.

Thus nitroglycerine is exceedingly unstable, and the same is true of nearly all the latest and most powerful explosives, such as the trinitrotoluenes. In fact, we might almost state as a general principle, that in proportion as an explosive is powerful, and its destructive effect great, in the same proportion is it unstable, so that its stability has to be increased by mixture with an inert substance, as when dynamite is made from nitroglycerine by the addition of silicon material.

Now the only way we can conceive this explosive power to arise is from the aether. It cannot come from the substance of the explosive itself. But if the aether be 689321600000 more elastic than air in proportion to its density, and the universe be filled with waves of all lengths, — then obviously a release of stress, in the rearrangement of structure which gives less resistance to the passing waves, will yield such sources of power as philosophers have seldom dreamed of.

In his familiar lectures on scientific subjects, 1867, pp. 282-286, Sir *John Herschel* recalls this tremendous power of the aether and adds:

»Do what we will — adopt whatever hypothesis we please — there is no escape, in dealing with the phenomena of light, from these gigantic numbers; or from the conception of enormous physical force in perpetual exertion at every point, through all the immensity of space.« . . .

»If free to expand in all directions, it (the aether) would require a bounding envelope of sufficient strength to resist its outward pressure. And to evade this by supposing it infinite in extent, is to solve a difficulty by words without ideas — to take refuge from it in the simple negation of that which constitutes the difficulty. On the other hand, such a 'crystalline orb' or 'firmament' of solid matter conceived as a hollow shell of sufficient strength to sustain the internal tension, and filled with a medium attractively, and not repulsively elastic, might realize (without supposing a solid structure in the contained aether) the condition of transverse vibration.«

This penetrating reasoning of Sir *John Herschel* shows clearly that the power of the aether everywhere about us is great enough, if made effective by molecular rearrangement, to call forth unlimited explosive forces. It is therefore logical to assign explosive forces to the power of the aether — just as we assign the power of the lightning to the release of aether stresses at the boundaries of condensing drops of rain when the aether waves come from every direction in this all-pervading medium.

That which explains the power of the thunderbolt will also explain the power of dynamite, the trinitrotoluenes, and other terrific explosive forces, which so long has challenged the ingenuity of the most eminent natural philosophers. It is impossible to consider the problem of explosive forces,

after a study of the wave-theory of lightning, without reaching the conclusion that the source of power in the two cases is one and the same. And as lightning, with all the destructive power of the thunderbolt, is definitely referred to wave-action incident to the release of aether stress at the surface of rain drops, we must also hold that explosive forces derive their stupendous power from the release of stresses in the aether incident to rearrangement of molecular structure. Hence the instability of all high explosives.

It only remains to point out that as there is yielding and collapse of the molecular structure in an explosion, it follows that such collapse of the original structure will lead to the atoms being carried not only into a state of greater compactness, but also to a rebound from this unnatural state of compression. This is the molecular structural oscillation, under the stress of the passing aether waves, which calls forth the terrific exertion of force witnessed in explosions.

The aether is almost infinitely elastic, and nearly incompressible. Therefore when the stresses incident to the waves binding together the parts of the molecule are released, the yielding carries with it a compression of the disconnected atoms, and in the oscillation the most tremendous forces inevitably are exerted.

It is highly unphilosophical to attribute these explosive forces to the substances themselves. They arise from the aether (*Αἰθήρ*) which *Sophocles* (*Oedipus Coloneus*, 1470) makes the seat of a terrific thunderstorm; and of which *Aeschylus* (*Prom. Vinc.*, 1103-1120) speaks prophetically:

»Yea, now in very deed,
No more in word alone,
The earth shakes to and fro,
And the loud thunder's voice
Bellows hard by, and blaze
The flashing levin-fires;
Such is the storm from Zeus
That comes as working fear,
In terrors manifest.
O Mother venerable!
O Aether! rolling round
The common light of all.«

6. Radio-Activity and Organic Growth and Decay furnishes Direct Evidence of the Wave-Theory.

(i) Radio-active substances are those which transform waves unsuspected and insensible to our perceptions, into others which may be observed, and thus such substances appear to radiate almost unlimited quantities of energy.

The mystery attaching to radio-activity has excited the interest of many ingenious experimenters, and during the past 25 years an extensive literature has been developed dealing with this subject. But notwithstanding the labor and ingenuity of many eminent natural philosophers, it can hardly be said that we yet have any satisfactory theory of radio-activity.

It is recognized that radio-activity involves the expenditure of large amounts of energy; and great emphasis has been laid upon the enormous amount of energy inherent in the atoms of matter. In the article on the Sun, *Encycl. Amer.*, 1904, Professor *Newcomb* dwells on the modification of

Helmholtz's contraction-theory of the sun's heat by the discovery of radio-activity, and says that recent researches show that there is a vast amount of energy inherent in matter, and that its release prolongs the radiation of the sun and stars much beyond the periods formerly calculated. Thus instead of 20 million years of solar radiation, we have energy available for periods to be reckoned in corresponding billions of years. The available energy of the universe has been increased a thousand fold.

It will be noticed that this reasoning places the source of energy in matter, whereas the wave-theory places the source of energy in the aether itself, which fills the universe, and has an elastic power 689321600000 times greater than that of air in proportion to its density. The amount of energy in the aether is unlimited, but only a part of it is available, depending on our material mechanism for converting it into visible energy, as in the electric current generated by a dynamo, or the molecular energy in capillarity, cohesion and in chemical affinity, so powerfully exhibited in explosive forces.

Sir *J. J. Thomson*, Sir *Oliver Lodge*, Sir *Ernest Rutherford* and others have made rough attempts to evaluate the amount of these so-called atomic energies. Conclusions have been reached that the amount of energy in a milligram of radium salt would be capable of doing an enormous amount of mechanical work, such as propelling a large ship involving the expenditure of a vast number of horsepower hours, or months.

But although I differ from these eminent authorities reluctantly, I must add that it appears to me probable, if not certain, that the foundation of their argument is of doubtful validity. Having reached the conclusion that waves exist of all possible length, from many metres or kilometres, down to atomic dimensions; and having found that the waves undergo transformation in passing through certain substances, I have ventured to raise the question whether we may not look upon radio-active substances as those which transform and render sensible to observation waves otherwise unsuspected to pervade the world.

If that idea be admissible, it will follow that the energy noted in radio-activity does not really reside in the atoms which are radio-active, but is merely made manifest by the transformations of waves traversing these atoms.¹⁾ It is probable, perhaps certain, that some atoms have the power of rendering sensible waves which otherwise are insensible. Phosphorescence is a familiar illustration of this tendency. Again we see evidences of a similar tendency when X-rays pass through a thin layer of tungstate of calcium, whereby visual rays are produced in the field traversed by the X-rays, so that the whole field of operations may be explored by the eye.

With the X-rays alone in free space the field is without material resistance and so quiescent that light waves of sufficient intensity to give distinct vision do not arise. Yet when the

X-rays are sent through the field, and finally traverse a layer of tungstate of calcium, objects in the field become illuminated; and we can see distinctly along the path of the X-rays.

The writer's theory of the X-rays is that they are fairly long waves, which thus penetrate various objects. And under the agitation these long waves are either broken up into shorter ones, — corresponding to the visible spectrum, with the ultra-violet part, which gives the photographic power to the X-rays, — or shorter waves are called forth in the atoms all along the line.

We know that atoms are oscillating systems and have a high power of resonance; and this theory of longer waves breaking up into shorter oscillations or calling forth shorter waves, is in accordance with modern researches on the structure and periodicity of the atoms.

If these views be admissible, it will follow that just as calcium tungstate renders the waves in an X-ray field visible to the eye; so also may other radio-active matter in like manner transform invisible waves always pervading the universe into perceptible waves. The waves thus rendered sensible to experiment would give a field of research like that characteristic of radio-active substances.

By way of illustrating this theory of natural wave transformation we may call attention not only to phosphorescence, in organic bodies under decay, and in living objects like the fire-fly and the glow-worm; but also to many phenomena of luminescence in the physical universe, such as the luminous night clouds, which have been especially studied in Germany, the general prevalence of the Aurora Borealis in all latitudes, which *Slipher* has investigated photographically (cf. *Lowell Observ. Bull.*, No. 79, and the author's *Electr. wave-theory of phys. forc.*, vol. 1, 1917, p. 48).

Then again there is similar evidence of luminescence in the nebulae. Many of these objects must be intensely cold, because we can see very faint stars through them; and we know such transparent nebulae can no more retain heat than can the tails of comets, which are known to be at the temperature of space, yet shine with a glow suggestive of phosphorescence, or the Geissler-tube.

As electric discharges in the Geissler-tube may call forth ample light, though no sensible temperature is evolved, and an electric current is recognized to consist of ordered waves, in the aether, we see at once why the tail of a comet might glow in the electro-magnetic field of the sun. The wave-field of the sun is so filled with waves of all possible length that if the particles of a comet's tail had any power of resonance, luminosity ought to develop near perihelion passage.

Now the tails of comets do become enormously brilliant at the nearest approach to the sun; and the luminosity of the tail dies down as the comet recedes away into space. The amplitude of all waves from the sun follows the law:

$$A = k/r \quad (20)$$

¹⁾ In a profound paper "On the absorption of light by coloured media", Sir *John Herschel* has outlined the effects of aether wave motion through material bodies so clearly that we quote it:

"Now, as regards only the general fact of the obstruction and ultimate extinction of light in its passage through gross media, if we compare the corpuscular and undulatory theories, we shall find that the former appeals to our ignorance, the latter to our knowledge, for its explanation of the absorptive phenomena."

The question 'What becomes of light' for *Herschel* is converted into 'What becomes of motion'. "And the answer, on dynamical principles, is, that it continues forever."

and the energy of the waves varies as the square of the amplitude

$$E = A^2 = k^2/r^2. \quad (21)$$

Accordingly the power of the waves to develop luminosity ought to increase and diminish almost directly as the power of the sun's radiation, when the comet approaches and recedes. This conclusion is in general accord with observation. In much the same way the permanent luminosity of the nebulae may depend on the transformation of waves otherwise largely invisible. The evidence of celestial radio-activity is therefore ample, but not exactly of the type noted under experimental conditions in our laboratories.

(ii) Animal and plant growth and decay represent transformations of energy, and thus point to wave-action.

After the foregoing development of the wave-theory this subject is so obvious that an extended argument seems superfluous. We therefore merely call attention to certain leading facts.

1. Animal and plant nutrition go on under the action of chemical affinity and the molecular forces. And if these two types of physical forces be due to wave-action, it will follow that the nutrition due to chemical affinity and molecular forces are also due to wave-action.

2. The processes of nutrition consist in the preparation, for the breaking up of molecules of the food, in order to make the constituent atoms available as building material for the renewal of organic molecules which are undergoing decay, decomposition or combustion by oxidation in the organism. Thus the support of organic life requires a constant renewal of molecular and atomic energy, in the form of food prepared for such nutrition, which gives bodily energy and strength to the animal or plant.

3. In the case of plant life, the material taken in as food is largely inorganic, nitrogenous and other elements from the ground, carried up into the plant structure by the force of capillarity, which is a phenomenon of wave-action. These elements from the earth are borne in the sap, and thus distributed throughout the plant structure. But the plant leaves act as lungs, and absorb certain gases. These lead to the fixation of oxides and potash products in the plant structure. Above all, carbon dioxide (CO_2) taken from the air is effective in building up the organic structure of the plant.

4. The carbon from the CO_2 is built into the plant structure, so as to make fibre, while most of the oxygen is liberated again to return to the air. Thus growing plants purify the air of carbon dioxide. Their growth constitutes a chemical process or reaction, whereby organic structures having carbon as the main body of plant structure are built up, and when dried out may be burned, again producing heat and CO_2 .

5. It is well known that plants cannot live without air and sunlight. The sunlight, in concert with the longer heat waves, aids the chemical changes, whereby inorganic atoms are united and built up into organic molecules. In darkness, as we have often observed, a plant languishes, turns pale and finally dies: the chemical transformations of its life come to a standstill, as decay of organic circulation and nutrition fails. This failure is due to the cutting off of the shorter waves,

upon which chemical transformation mainly depends, so that without light plants cannot grow and flourish.

6. The finished plant structure is largely hydrocarbon, with certain mineral salts and water of nutrition. Cut off the water, and the plant withers, because the circulation and nutrition through capillarity and the chemical transformation by wave-action, in the form of light and heat, all come to an end. In the same way, if we intercept the main flow of capillarity, by cutting off the bark and laying bare the wood of a tree, it will soon die. This process of 'deadening' is much used by American farmers when they wish to kill the trees on uncleared land. And now we see that it all depends on intercepting the capillary flow, which is due to wave-action.

7. What applies to trees applies to almost all forms of plant life. Thus we see that if the capillarity, due to wave-action, and the chemical affinity for nutrition, under the action of heat and light waves, be seriously intercepted, the result is essentially fatal. Hence we hold that all vital phenomena in the plant and vegetable world depend on wave-action. This is the deeply mysterious power for renewal so long hidden from our sight, but operating everywhere for the support of life in organic nature.

8. The life of animals is more complex and varied, but the causes underlying its maintenance are in the main the same. The typical animal lives largely on plants, in one form or another. Hence wave-action develops plants, and their digestion or decomposition under various chemical reactions, furnishes food or nutrition, which is made to nourish and support the strength of animal bodies, and all their varied activities.

9. Most of our common animals have animal heat, and hence the chemical combustion of their food is maintained by oxygen breathed in through the lungs. We shall not here treat of fish and other forms of life with low temperature, which have different vital processes, as these are treated of in works on biology. It is evident therefore that animal nutrition depends on wave-action quite as much as plant nutrition. Food is taken into stomachs, and subjected to the chemical reaction of juices, at appropriate temperature, and thus the transformations are connected with wave-action.

10. The longer waves of the world go through animal bodies quite unperceived, and stimulate the shorter waves, on which chemical action depends. Thus our theory of the X-rays being short waves maintained by the action of longer and more penetrating waves (cf. AN 5079, p. 292), finds confirmation in the processes of animal and plant nutrition.

We have been unaccustomed to view the vital processes of the world as due to wave-action; but if molecular and chemical forces depend on the energy of waves in the aether, we shall obviously have to change our old way of thinking.

11. Our new theory of magnetism and electrodynamic action, under which aether waves penetrate all objects, has led a learned thinker, Rev. *Paul Camboué*, S. J., of Tananarive, Madagascar, to suggest that love and other emotional influences in animals, and in man, depend on aether waves emanating from and directed by bodily senses and organs, not unlike the influences of magnetism in inorganic nature. In fact I have held somewhat similar views for some years, including

the conviction that thought is an electric process sustained by waves, and have considered more especially mental and telepathic suggestions as coming under the domain of wave-phenomena¹). The connection of these theories with mental and spiritual and psychic phenomena is obvious, but we leave the development of the subject to those who make a specialty of psychic phenomena.

12. It is of course recognized that bodily senses and organs, by the nature of our nervous system, are largely under the control of the will. But even so, the power of suggestion may be conveyed by wave influences directed by different individuals; and thus a great domain of wave-action is seen in aesthetics and social life, heretofore but little understood.

If one magnet can by the concerted vibrations of its atoms draw those of another piece of metal into harmonious accord, so that the second piece of metal responds to the waves from the first, a similar power of response for the development of emotional harmony may exist in living beings. Here, again, the field for speculation is very great, but we must content ourselves with the physical laws, and leave the applications of the laws to those best qualified to deal with psychic and emotional influences.

It is, however, of some interest to note the immensity of the domains of science opened up by the new theory of the aether. Indeed the unexpected impression now drawn from most obscure subjects will lead us to reflect that the aether is the bearer of light for illuminating the organic as well as the physical world.

(iii) All vital phenomena depend on chemical action and thus on wave-action, which also builds crystals and deposits ores by electrolysis.

Some fifteen years ago Professor *Jacques Loeb*, then at the University of California, but more recently of the Rockefeller Institute for Medical Research, New York, told me that in his judgement all vital processes depend at last analysis on chemical action. He cited the fact that suspension of the supply of material required for nutrition is fatal; and that by varying the supply, and mixing it with various elements, a varied growth results, as shown everywhere by the great variety of organisms and their modification in nature.

Now Professor *Loeb* is perhaps the most eminent experimental biologist in the world. He produced parthenogenesis by the use of solutions containing certain chemical elements on frog eggs; and the frogs thus artificially developed were found to be normal, without the loss of any of their natural animal powers.

Accordingly, the high authority of Professor *Loeb's* opinion in a biological problem ought to be almost decisive that all biological processes depend chiefly and at last analysis on chemical action. But the variety of life and vital phenomena is so great that perhaps we shall consider this conclusion more probable if we note the elements upon which vitality depends:

1. We take life as existing, and shall not go into the discussion handed down through the centuries as to the origin of life. *Arrhenius* and others think the germs of it may have

come to us from other worlds; while some hold that it doubtless originated here by processes at present wholly unknown.

2. Life depends for its maintenance on four chief processes:

(a) Nutrition, or the absorption for chemical assimilation of various elements useful in body building.

(b) Digestive processes, by which the elements are prepared for nutritive processes, making absorption and nutrition easy, so that bodily strength and functions can be maintained.

(c) External chemical elements such as oxygen required for animal heat, and carbon dioxide for plants; which aid the maintenance of life, by maintaining heat, elimination, or body building.

(d) Regulation of chemical action, as these processes go on. And as the chemical action depends on wave-action, we see that the aether waves pervading the world are the chief element in regulating the progress of growth.

3. These four elements are the chief sources of vitality. And if we knew how to sustain the efficiency of these sources of power unimpaired, we should have the means of new vitality. In practice we are reduced to the problem of studying the most advantageous nutrition, improving the processes of elimination, but in some cases electricity may aid medical therapeutics, by the new stimulus thereby afforded by artificial wave action. This last use of electricity has considerably increased in modern medical practice; but the processes of nature are symmetrical, and living beings may have local stimulation more easily than general renewal.

4. In the third paper on electrodynamic action and magnetism, AN 5079, pp. 261-262, we have shown how *Ampère's* original theory of elementary electric currents circulating about the atoms may be reconciled with the wave-theory. In fact the wave-theory and *Ampère's* theory in many respects are identical. And if we conceive waves coming to a body from the atoms of another body, whose atomic planes have a haphazard orientation, the two systems of oscillations, atom for atom, will correspond, as in the theory of gravitational attraction. Each atom is to be conceived to oscillate in such a way that revolving contact occurs between its parts, or the system circulates periodically, the periphery thus giving circulation with the oscillation. The result of the revolving contact or periodic circulation is a wave flat in the atomic equator. Thus *Ampère's* theory of 1822 and the wave-theory are the same.

5. This vibration-theory of atoms is well known in spectrum analysis, and the *Ampère-wave-theory* enables us to interpret it mechanically, in a comparatively simple way. If the waves from the atoms can be maintained unimpaired their electrical vitality is steady as in permanent magnets. But in vital processes the work of nutrition has to go on, because of physical work done by animal organisms; and thereby the vibrational power of the atoms in the physical body may be impaired, partly by clogging the electrical conductivity, and partly by the short circuit and hysteresis effects, with natural waste of electric energy.

¹) In radio-telegraphy our apparatus has to be carefully attuned to give the best receiving and transmitting power. So also in psychic phenomena only those in rapport, in very close psychic accord, may send and receive telepathic messages. The wave-analogy seems very suggestive.

6. Thus vital phenomena depend on wave-action largely in the form of electric energy, — the wave energy of the aether pervading the entire universe. And just as battery action is not perfect and involves a certain amount of waste from physical deterioration — so also vital energy may decline under poor bodily nutrition and waste, which are inseparable from the work of life. A permanent magnet does not deteriorate, because the energy given out equals that received, when the atomic planes remain fixed. Yet in the electrolysis of the world, the electric action is not so unhindered, but constantly modified by chemical affinity due to other elements, as in vital processes, so that conductivity is constantly changing.

7. These remarks throw some light upon the processes of mineralogy and crystallization. Some twenty five years ago I heard that an eminent investigator of crystals had reached the conclusion that they are living organisms, not very unlike certain primitive types of plants and animals. Such a view then seemed very startling, but it now seems plausible if not demonstrated. It is certain that the building of crystals is an electrolytic action due to waves, and made effective when certain solutions are available for facilitating the electrolysis. Wave-action therefore underlies crystal-building just as it does all vital processes.

8. In spite of all our researches on minerals and metallurgical processes, we are still much in the dark as to the origin of ores in veins, and nuggets. Just why silver and gold, nickel and platinum, copper and iron should be deposited as they are in the earth's crust has never been satisfactorily explained. We shall not here go into the question extensively, but it may not be out of place to remark that electrolytic action is the only explanation worth considering.

9. Electrolytic action, in the form of electro-plating, explains the plating of silver on silver, gold on gold, copper on copper. Such electro-plating requires the metallic elements to be in solution, and a current to be maintained capable of effecting the deposits. Now the earth is a vast and varied laboratory, in which the chemical elements are variously mixed, and often dissolved in baths of liquid. And therefore if current action could be maintained it is more than probable that electrolysis analogous to electro-plating would go on; and even if the process be very slow, it would finally give us just such a variety of metallurgical phenomena as we actually observe in nature.

10. In proof of this electrolytic action, under the wave-action pervading the world, we need only cite the collection of gold nuggets in matrixes of quartz, and silver in corresponding characteristic rocks. The conditions which permitted these rocks to form, often with partial crystallization, have also permitted the earth's electrolytic action to deposit the gold and silver, dissolved in the solution of sea water, from the baths of the ocean overlying these rock formations. It is well known that sea water contains practically all elements in solution; and the processes of electro-plating under the wave-action of a current, is the only explanation of mineralogical phenomena suggested by chemical experience. All these phenomena are more closely related to vital phenomena than might at first sight seem probable.

Conclusion of the Wave-Theory of Chemical Forces.

The wave-theory of chemical forces follows from the wave-theory of molecular forces, as will be perceived by those who study this whole series of papers; and it appears that the present argument is not only strong in itself, but also gathers immense power from the argument developed in the preceding wave-theory of the larger physical phenomena. A satisfactory theory of the phenomena of nature will not be viewed with indifference by discerning natural philosophers.

Accordingly, we add merely a few suggestive considerations which may be of interest in the future development of this subject.

(α) *Fourier's* remark that heat travels incessantly equally suggestive in regard to other forms of energy.

It is well known that chemical processes are always at work, but it is well to examine this fact more closely, in hope of confirming the cause underlying this ceaseless law of change. In his celebrated *Théorie analytique de la chaleur*, 1822, *Fourier* exclaims:

«La chaleur pénètre, comme la gravité, toutes les substances de l'univers; ses rayons occupent toutes les parties de l'espace. . . . En effet, le rayon du soleil dans lequel cette planète est incessamment plongée pénètre l'air, la terre et les eaux; ses éléments se divisent, changent de direction dans tous les sens; et, pénétrant dans la masse du globe, ils en élèveraient de plus en plus la température moyenne, si cette chaleur ajoutée n'était pas exactement compensée par celle qui s'échappe en rayons de tous les points de la superficie, et se répand dans les cieux.»

Throughout this great work *Fourier* dwells on the incessant movement of heat, and gives the mathematical laws for this propagation. As heat is now known to be a wave-motion, *Fourier's* argument becomes of general application to the universe.

(β) The wave-theory of the growth of crystals and of metallic deposits of ores and minerals in the crust of the earth naturally follows from the wave-theory of chemical affinity.

The evidence adduced above for this conclusion could be much extended, but we deem it well to leave this discussion to chemists and mineralogists. It only remains to add that if our theory of tenacity be admissible, as shown in the fifth paper, then it follows that the wave-theory of electrolytic processes is beyond dispute. The aether is so stressed at the boundary of solid bodies that not only adhesion occurs, but also cohesion. This suffices to build up solid crystals, and furnish the powerful forces operative in electro-plating and in metallurgical processes.

Whether these world processes yield ores, nuggets, or metallic masses of larger size, I can not doubt that this wonderful process for producing in nature pure crystals, and pure ores, with nuggets of the precious metals, as of gold, silver, and platinum, are due to molecular separation and ordering under wave-action, as in our familiar process of electro-plating.

Considered from the point of view of its history through millions of years, the earth, with all the metals in solution in the sea, is an immense collection or bath of solvent elements, under the electric waves and other oscillations pervading

the universe¹⁾, and exhibited to us daily in the fluctuations of the magnetism, electrical disturbances and earth currents.

(γ) The doctrine of the conservation of energy and of the correlation of forces finds its best support in the wave-theory of physical forces. But this conservation should be understood to apply to all the energies of the universe — mental, spiritual, and subconscious, as well as purely physical. All ordinary vital phenomena must be referred to chemical processes, and thus to wave-action, on which the chemical forces depend. It has long been believed that electrical energy underlies vital phenomena, and now we have endeavoured to give valid physical grounds for this doctrine.

(δ) If our wave-theory of magnetism be admissible, it will follow that each individual carries a mental and spiritual wave-field with him, and hence the 'magnetic power' of certain persons. It is not our purpose to go into psychic or related phenomena, as this must be left to specialists in that large and important field of research. We merely point out that if magnetism and electrodynamic action be referred to waves from atoms, which under certain conditions act in concert, we shall have to admit that each person may be able to exert 'personal magnetism' and emotional influences, depending on waves in the aether, somewhat analogous to physical magnetism.

The subtle psychic influences operating through the all-pervading aether are as yet but imperfectly understood; and until the field is more fully explored we must preserve an open mind, as the first duty in scientific research, which aims not at popularity, but at truth, which endures unto all generations.

Part II.

Discovery of the Cause of Universal Gravitation.

In concluding the new theory of the aether it only remains to draw attention to the discovery and demonstration of the cause of gravitation, which results from this new theory, and the similar researches published during 1917, in volume 1 of the Electrodynamic wave-theory of physical forces. The new theory of the aether affords the necessary and sufficient conditions for a definite proof that wave-action underlies the chief operations of nature.

First, we analyse the facts of planetary observation in accordance with the inductive method which enabled *Kepler* to discover the laws of planetary motion, 1609–1619.

Second, we point out the steps and the physical and geometrical criteria by which *Newton* deduced from these facts of observation the law of attraction for universal gravitation.

Third, the phenomenon of acoustic attraction, for waves of air traveling past a balloon of CO_2 , is simple and easily understood, from measures of velocity in the theory of sound; and thus we naturally apply a similar aether-wave-theory to the observed attraction of universal gravitation. The inductive method, applicable to terrestrial gases which may be experimented upon in our laboratories, thus may be extended to the aether, in which the wave-action of universal gravitation takes place; and the similarity of the wave-processes in the

two cases is so close as to be truly remarkable. It appears from geometrical criteria, that such wave-action alone will explain universal gravitation; and thus we deduce the cause involved, and bring out the necessary and sufficient conditions based on physical and geometrical laws of unquestioned validity.

7. Recognized Geometrical and Physical Criteria Analysed by the Method of *Kepler* and *Newton*. Foundations for the Discovery of the Cause of Universal Gravitation thus incontestably established.

(i) Brief statement of *Kepler's* laws and of *Newton's* deductions therefrom.

It is well known that *Kepler* used the observations of *Tycho Brahe* to deduce the observed laws of the planetary motions; and that *Newton* subsequently deduced the law of gravitation mathematically from the physical facts formulated in *Kepler's* laws. When *Newton* had thus deduced the law of attraction for the force of universal gravitation, he was able in turn to show that *Kepler's* laws follow from the law of this force varying inversely as the square of the distances, and even to correct *Kepler's* third law, which was not quite accurate as originally given, — *Kepler's* form being $t^2 : t'^2 = a^3 : a'^3$, whereas it should read

$$t^2(1+m) : t'^2(1+m') = a^3 : a'^3. \quad (22)$$

After the course of reasoning laid down by *Kepler*, *Newton* derived geometrical criteria, to supplement *Kepler's* physical criteria, which proved both necessary and sufficient to establish rigorously the law of the forces governing the planetary motions. On account of the historical importance of this development, and its bearing on the related problem of the cause of gravitation, which we deduce by an analogous method, we shall examine the reasoning of *Kepler* and *Newton* with some care.

In the work on the Motion of mars, 1609, *Kepler* announced, in substance, the following laws as observed physical facts:

I. The orbit of the planet is an ellipse, with the sun in the focus.

II. The radius vector of the planet drawn to the sun's centre describes equal areas in equal times.

III. And in the work *De Harmonice Mundi*, 1619, the third or harmonic law: The squares of the periodic times of the planets are as the cubes of their mean distances, or $t^2 : t'^2 = a^3 : a'^3$ — the slightly corrected modern form being

$$t^2(1+m) : t'^2(1+m') = a^3 : a'^3. \quad (23)$$

Tycho's observations of mars, and the considerable eccentricity of the orbit of that planet had enabled *Kepler* to reject the traditional Ptolemaic theory of eccentrics, and substitute therefor the theory of planetary motion in an ellipse. So daring an innovation cost *Kepler* great labor, because it involved very tedious calculations. As his work was done before the invention of logarithms, these calculations could not then be abbreviated, as they have been for later investigators. Accordingly, *Kepler* declared that *Napier's* invention of logarithms had trebled the lives of the astronomers.

¹⁾ When we observe the phenomena of nature and note the infinite variety of exquisite colors, some due to absorption, some to refraction and dispersion, and others to interference, we wonder indeed that the wave-theory was not long ago suggested to investigators. Accordingly, if there be those who hesitate to grant the truth of the theory, we need make but one remark: Behold the order of nature, with the infinite varieties of colors in the heavens and in the earth! Has this beautiful order no meaning to those who have eyes to see?

We see therefore that *Kepler's* first law is mainly concerned with getting away from the Ptolemaic hypothesis of eccentrics and epicycles, which the discoveries of *Copernicus* had largely but not entirely swept away.

The second law of *Kepler* has a very different import, namely, the equal areas described in equal times points to a central force acting on the planet and directed to the sun's centre. It is well known and easily demonstrated that however the law of force may vary with the distance, so long as it is central, the areas described by the radius vector will be equal in equal times. This law of areas would hold for any law of attraction,

$$f = k/r^n. \tag{24}$$

If the law should change, as from $n = 1$ to $n = 2$, the areas described would still continue to be equal, but the form of the curve in which the planet moved would undergo a change with the change in the law. Thus when $n = 1$, the curve is an ellipse, with the sun in the centre, but with $n = 2$, the curve is an ellipse with the sun in the focus, corresponding to the planetary motions observed in nature.

Finally, after the second law showed that the force is central and directed to the focus, the third law of *Kepler* enabled *Newton* to deduce the law of this force. *Newton* proved that it must vary inversely as the square of the distance. On the observed facts of *Kepler's* laws no other law of force is admissible.

But in establishing the law of gravitation, (*Principia*, 1686) *Newton* proceeded with his usual caution and philosophic acuteness. For he not only showed that if the planet move in an ellipse with the sun in the focus, the force of attraction will conform to the law of universal gravitation; but also investigated the effect of a slight departure from the law of the inverse squares (cf. AN 5048, pp. 144-153).

Thus if we take

$$f = k^2/r^{2+\nu} \tag{25}$$

where the gravitational exponent is changed by adding ν , a very small quantity, *Newton* pointed out that the result would be a forward motion of the perihelion. Hence already in 1686 he foresaw the possibility of a shifting perihelion, — such as *Leverrier* discovered for the planet mercury in 1859, which has since led to many unprofitable speculations on relativity.

Yet as the observations in *Newton's* time pointed to the fixity of the perihelia (*Principia*, Lib. III, Prop. XIV), this great philosopher believed the law of attraction to be rigorously as the inverse squares. Accordingly, it will be seen that the investigations of *Tycho's* observations led *Kepler* to the laws of planetary motion, as facts of nature; and upon the basis of *Kepler's* laws further geometrical researches led *Newton* directly to the law of universal gravitation. The physical facts of nature being as stated in *Kepler's* laws,

Newton's geometrical criteria were necessary and sufficient to show that the force of attraction obeys the law of the inverse squares, and no other.

During the past three centuries the historical development here traced always has been regarded as the best and most rigorous example of the true processes of scientific discovery. The facts being given, as found by *Kepler* from *Tycho's* observations, the question was: What law of attraction will explain these facts, and is this the only admissible law of attraction?

Newton answered both of these questions in the affirmative, and no one ever has been able successfully to challenge the results of his mathematical researches.

The recent speculations of *Einstein* may be disregarded, because they are totally lacking in physical basis¹). *Newton* based his reasoning on the foundation of facts laid down by *Kepler*, which was as solid as granite; and hence the past three centuries have witnessed an unprecedented development of celestial mechanics. Since the time of *Laplace* the *Newtonian* law has been regularly used as a means of discovery as certain as observation itself.

If we contrast this careful procedure, with correct reasoning on valid premises, and compare its logical results with the reckless course of *Einstein* in proposing to do away with the aether, — as if the planetary forces were not real, — and a medium capable of sustaining stupendous stresses were not necessary for their transmission across space, — we shall perceive that the whole theory of relativity is nothing but a flimsy foundation laid in quicksand. In this whole theory of relativity there is not a trace of substantial physical truth.

(ii) In acoustic attraction the air particles under the wave agitation work out from between the balloon of carbon dioxide and the source of the sound, so that there is tension between, while the pressure is increased behind the balloon. In the same way the aether waves from each of two heavenly bodies expel aetherons from between the masses, thereby generating tension, at the same time increasing the pressure beyond, thus giving rise to the attraction of universal gravitation.

The mechanism of attraction, in the case of acoustic attraction, has been clearly made out in the fifth paper on the new theory of the aether (AN 5130), and we have illustrated this mechanism by means of a chart of the wave front which is so clear and distinct that no doubt can arise as to the nature of the cause assigned. The figure is here repeated, in order that the image of the wave front may be recalled to our minds with entire distinctness (Fig. 12, plate 7).

It is evident that as the sound travels faster in air, $V = 1.00$, than in the balloon filled with CO_2 , $V = 0.78$, the wave agitation in the air will outrun that through the

¹) In AN 5079, p. 257, we have shown the inadmissibility of *Gerber's* formula for the potential, which underlies *Einstein's* theory:

$$V = M[r(1 - 1/c \cdot dr/dt)^2]. \tag{a}$$

In the Treatise on electricity and magnetism, 1873, section 856, *Maxwell* has successfully defended the validity of *Weber's* law, of which the potential is

$$V = (k^2 mm'/r^2) \cdot [1 - 1/c^2 \cdot (dr/dt)^2]. \tag{b}$$

The second term gives the effect due to motion in a wave-field, the work of transforming the potential energy changing, like the kinetic energy, with the square of the planet's velocity relative to the sun. If $dr/dt = 0$, as in circular orbits, the *Newtonian* law follows; but more generally the velocity in the direction of the radius vector dr/dt yields a term for the effect of the induction, and d^2r/dt^2 gives the term for the change of the induction, under motion in the wave-field. Thus *Weber's* law is the fundamental law of nature, and from (b) we have:

$$f = -\partial V/\partial r = (k^2 mm'/r^3) \cdot [1 - 1/c^2 \cdot (dr/dt)^2 + 2r/c^2 \cdot d^2r/dt^2]. \tag{c}$$

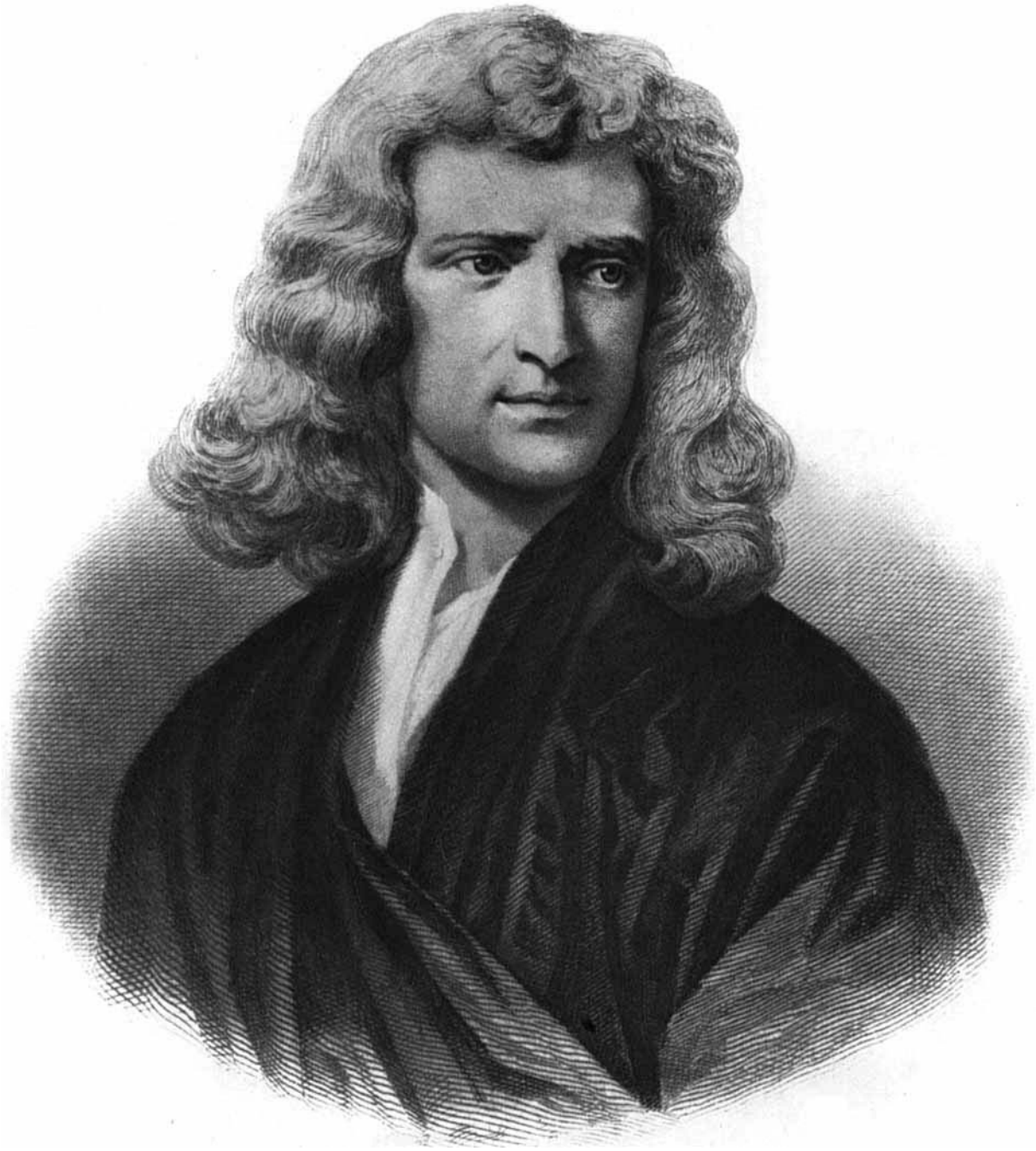

Is. Newton
"Hypotheses non fingo"

Sir Isaac Newton

1642-1727

balloon. Thus for every phase of the waves, the agitations reach the back of the balloon through the air before they arrive straight through that denser and less rapidly conducting medium. The effect is to bend the wave front into oppositely directed eddies behind the balloon, and the incessant advance impulses of the waves, — thus turned out of the ir-rectilinear course, and stopped by the mutual impact of the eddies, — give such agitation or increase of pressure behind that the balloon is shoved forward towards the source of the sound.

As the particles tend to work around behind the balloon, it may be said that the air is thinned out between, when the particles are carried around behind; so that there is tension in the medium between the balloon and the source of the sound. On the other hand the crowding of particles in behind the balloon, by the constant bending of the front as the waves flow steadily around it, and the impulses are destroyed, has the effect of an increase of pressure on the back of the balloon. It is shoved forward by the kinetic energy of these impulses. And thus it may be said that at last we have experimental proof that attraction is due to a vis a tergo — a shove from behind, which is a very old doctrine in natural philosophy, but heretofore not capable of obvious demonstration, in simple phenomena admitting of but one interpretation.

Now in the case of the aether waves receding from two heavenly bodies, it is evident that the waves from each centre will aid in expelling the aetherons from between the masses. In AN 5048, p. 156, we have given the following figure to illustrate the refraction of the sun's gravitation waves in traversing the solid globe of the earth.

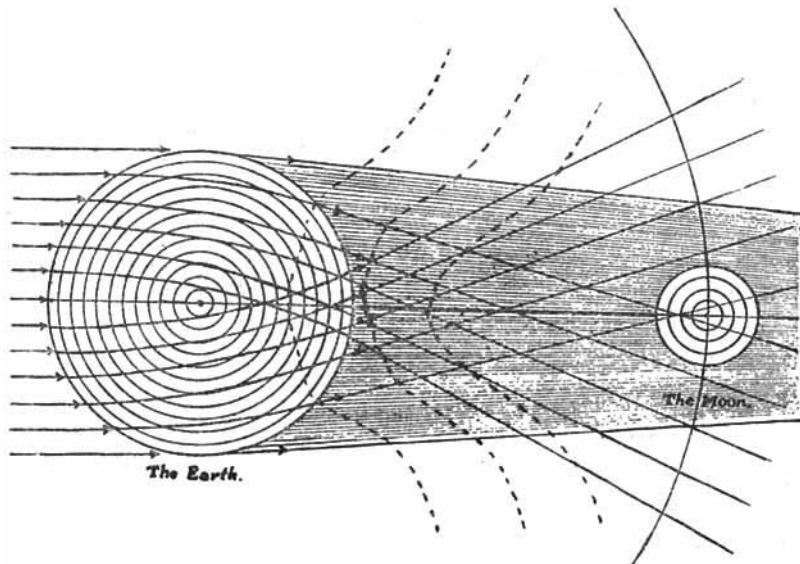

Fig. 13. Illustration of the refraction of the gravitational waves of the sun in passing through the globe of the earth, from the *Electrodynamical wave-theory of physical forces*, vol. 1, 1917, p. 88. The refracted wave-front is here indicated by pointed lines, to complete the analogy with sound, refracted around the balloon filled with CO_2 , and shown in Fig. 12, plate 7.

It will be noticed that the waves from either side are refracted towards the axis of the earth's shadow, just as in the case of the acoustic attraction illustrated above. This is a very remarkable analogy which deserves careful study.

We may easily convince ourselves of the validity of this figure by the following considerations.

1. The refraction of the sun's gravitational waves in passing through the earth, as illustrated above, is postulated on the increase in the density of the layers of the globe as we approach the centre, which is a well established physical fact, — since the surface density is only about 2.55, while the average density for the whole globe, according to the most careful experiments is about 5.50.

2. But quite aside from the increase of density in the layers as we approach the centre, it is well known that in all cases waves travel faster in free space than through any solid mass whatever. Thus the wave front on either side must be refracted towards the axis of the shadow, not only within the globe, but also outside of the earth, very much as in the case of the sound waves about the balloon of carbon dioxide treated above.

Accordingly, we see that the explanation of acoustic attraction affords a tangible explanation of the development of tension between two heavenly bodies, and the increase of pressure beyond them. The air is a kinetic medium, like the aether, only the aether is 689321600000 more elastic in proportion to its density. Hence the aether is capable of exerting tremendous stresses, for governing the motions of the planets.

Finally, it only remains to add that in light the oscillations of the aetherons are in the normal to the wave front, and thus similar to those of sound as held by *Poisson*, 1830, (cf. AN 5085), but the waves are flat only in the planes of their equators, and under haphazard arrangement of the atomic planes only the part $q = 1/40$ in the direction of the radius, while the ratio of A/λ is excessively small, making the longitudinal component evanescent

$$A = q \cdot A/\lambda = 1 : (66420 \cdot 10^6); \quad (26)$$

so that the longitudinal component is utterly insensible to observation. As the displacements of the aetherons are similar to those of the particles of air in sound it follows that the bending of the aether wave-front is similar to that shown in the above diagram of the wave-front for sound waves bending about the carbon dioxide balloon.

In all these aether waves there is true radial displacement of the aetherons, as of the particles of the air, when sound is traveling outwardly from a source; and thus the analogy between sound and gravitation is complete in every respect. Accordingly, we perceive that the aetherons are so worked out from between the two heavenly bodies, that tension exists along the right line connecting them, while beyond them there is increase of pressure, as correctly held in the *Electr. wave-theory of phys. forc.* vol. 1, p. 136.

8. The Inductive Method of Discovery as applied to the Aether leads to Wave-Action as the Sole Cause of Universal Gravitation.

(i) The *Kepler-Newton* method applied to the new theory of the aether.

We have now traced the procedure of *Kepler* and *Newton*

and shown that from certain well established facts of nature they deduced definite laws of the planetary motion, all depending on the attraction of gravitation.

The question now is: Can this *Kepler-Newton* method be applied to the kinetic theory of the aether, to deduce rigorously the cause of universal gravitation?

For as *Newton* made rigorous use of the facts stated in *Kepler's* laws to establish the law of gravitation, it is natural to inquire if the *Kepler-Newton* process can be so extended in the theory of the aether as to enable us to deduce rigorously the cause underlying universal gravitation.

We approach this problem by successive steps as follows:

1. It has been shown in AN 5044, p. 53, that the density of the aether is not uniform throughout space, but increases away from a heavenly body, because the amplitude of the waves receding from any spherical body such as the sun follows the law:

$$A = k/r. \quad (27)$$

2. Accordingly, if the medium be agitated by waves, their amplitudes increase towards the centre inversely as the radius, so that under the agitations of the waves the density decreases towards the centre, and increases as we go outward into space, directly as the radius:

$$\sigma = \nu r. \quad (28)$$

3. The following figure shows the curves for the wave amplitude, which are rectangular hyperbolas referred to their asymptotes.

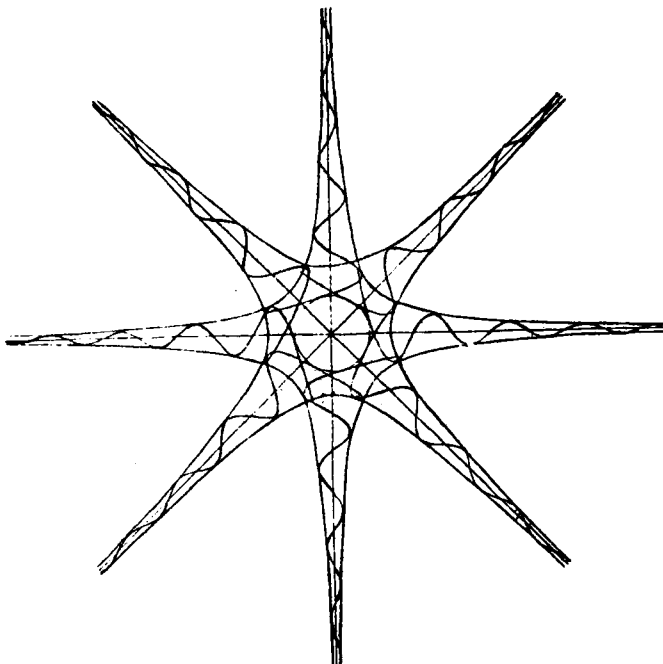

Fig. 14. Diagram showing graphically the increase of amplitude towards the sun, and thus a corresponding decrease of the density of the aether, owing to the asymptotic increase in wave amplitude as we approach the centre.

These curves follow from the nature of wave expansion in tridimensional space, and the asymptotic law of the amplitude thus holds rigorously true.

4. Apparently the only way we can deny the heterogeneity of the aether is to reject this diagram by denying that waves exist; yet this is increasingly difficult because of the following phenomena:

(a) Light and heat waves certainly radiate from the sun, and these waves follow the law shown in the diagram. Thus if the aether were agitated by waves of light and heat alone, it could not be homogeneous, because of the increased amplitude of the waves towards the sun's surface.

(b) It is shown in our theory of magnetism that magnetic forces depend on waves, and obey the law of amplitude indicated above. Thus cosmical magnetism also is a wave-phenomenon, and observation shows that magnetic storms are due to masses of magnetic waves proceeding from the sun, and thus very conspicuous when certain solar areas are uncovered, as by sunspot development.

(c) A paper by Professor *W. Grylls Adams* in the Phil. Transact. of the Roy. Soc. for 1892, A, plate 8, seems to show that these magnetic disturbances occur simultaneously throughout the terrestrial globe, as if the disturbances depended on commotions in the sun. These disturbances are accompanied by aurorae and earth currents, which can only be explained by a solar origin.

(d) The connection between sunspots and magnetic storms is shown over a period of two or three centuries, and emphasized by our latest researches with modern data, as by the writer's paper bringing *Wolf's* curves down to 1916, Bull. of the astron. soc. of France, November 1918, pp. 397-402.

(e) During the year 1920 much discussion arose in the radio-telegraphic circles of London as to the origin of very delicate but incessant electric commotions sensible to our modern apparatus. In an interview with the public press I expressed the opinion that the reported disturbances depended primarily on commotions in the sun, which caused corresponding oscillations in our terrestrial magnetic field. Within about two weeks of this discussion in America, press dispatches from Paris and London stated that the French and English men of science concurred in the view that these disturbances of our wireless receivers depend principally on the commotions always going on in the sun.

5. Thus we are driven by a great body of knowledge to admit that electrodynamic waves must come to us from the sun.

(a) If so, the aether cannot be homogeneous, but must follow the law of density

$$\sigma = \nu r \quad (28)$$

because of the increasing amplitudes of these waves towards the sun.

(b) Waves offer the only known explanation of magnetism and electrodynamic actions, with the law of amplitude,

$$A = k/r \quad (27)$$

and the law of force,

$$f = A^2 = k^2/r^2. \quad (29)$$

(c) In the same way the wave-theory explains *Biot* and *Savart's* law, *Ohm's* law, and the mechanical cause underlying the pointing of the needle to the north pole, — whilst no other theory supplies this obvious defect, involving so many electrodynamic phenomena.

T. J. J. See. New Theory of the Aether.

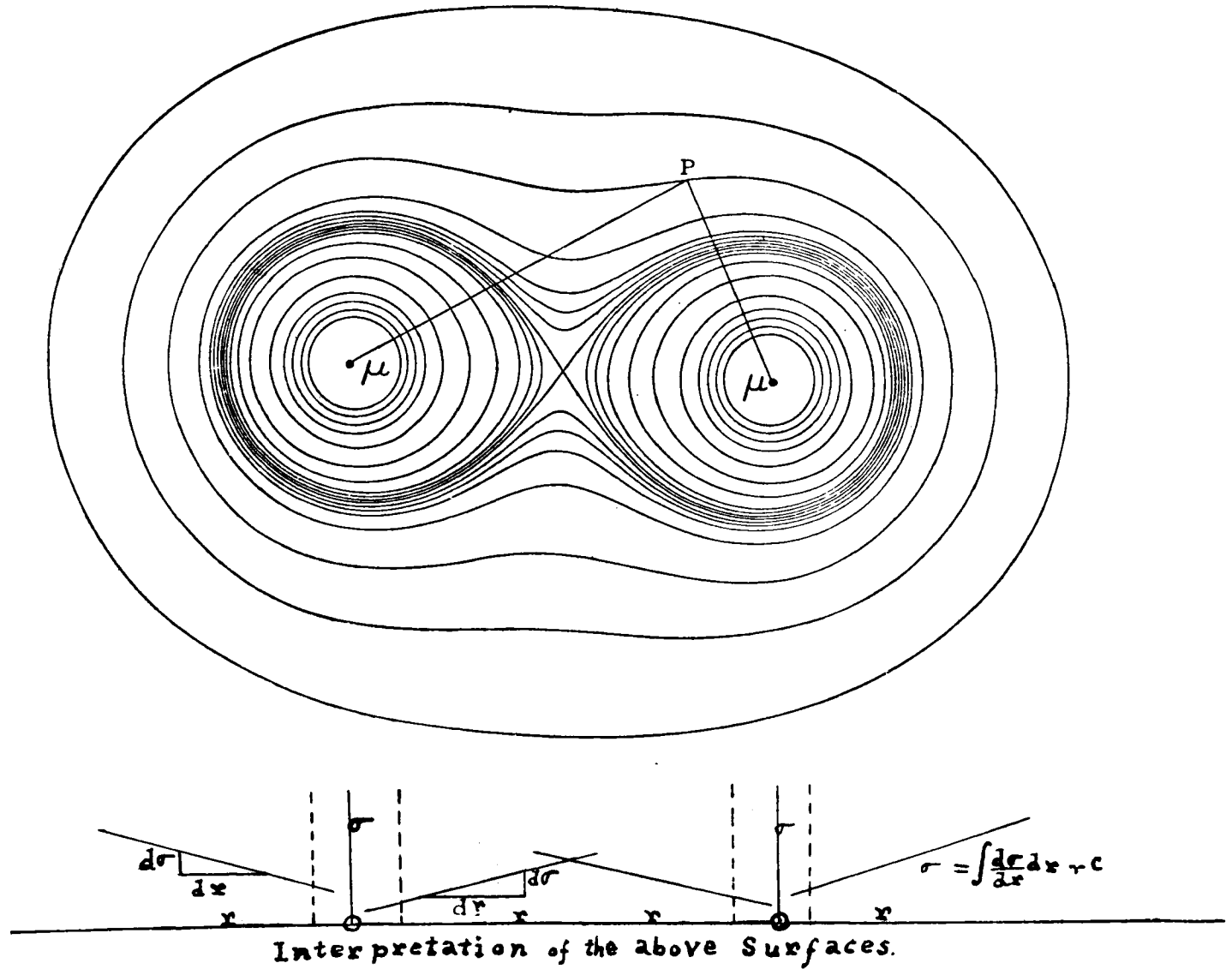

Fig. 15. Diagram of the equipotential surfaces about two equal masses, μ and μ , originally given in *Thomson and Tail's Treatise on Natural Philosophy*, 1st ed. 1873. Without regard to the cause involved this diagram represents the actual surfaces which exist under the potential of gravitation; and in the light of the new theory of the aether we now interpret the meaning of the distortions shown which were first published about half a century ago.

(d) *Weber's* electrodynamic law implying waves traveling with the velocity of light, explains the magnetic tides of the earth, whilst no other law meets this rigorous requirement.

6. Accordingly, we see that the wave-field traced in the above diagram gives us an accurate picture of the arrangement of the aether about such a central body as the sun. The density of the aether increases directly as r , when we go outwardly from the centre. It will follow a similar law about a spherical mass such as another star; and hence these curves of wave amplitude may be made to yield valuable criteria. For example the equipotential surfaces about a homogeneous sphere or a heterogeneous sphere made up of concentric layers of uniform density, are sphere surfaces, yet for a second body the wave-fields interpenetrate and the surfaces are changed in a significant way.

(ii) The geometry of the equipotential surfaces based on the law of gravitation points directly to the cause of this great force, and indicates its mode of operation for producing the chief phenomena of nature.

1. Now when we calculate the equipotential surfaces about two equal stars, μ and μ , we find that they have the form shown in fig. 15, plate 8.

Thus it will be seen that the surfaces closed about each centre in a pair of equal stars are not spherical, but actually distorted as shown in the figure. Each body stresses the aether so as to pull the surfaces enclosing the other body into egg-shaped surfaces, set end on, and where the two surfaces join we have an hourglass figure.

2. Thus the disturbing influence generates egg-shaped equipotential surfaces enclosed about either centre, and they have ceased to be spherical, and become so distorted in the direction of the other body that the radius vector is very appreciably longer than when either body acted alone; whereas, beyond, on the side opposite to the other body, the radius vector is shorter than it would be if the other body were absent. In other words the gravitational forces are compounded as shown in the following figure, and the equipotential surfaces thus increasingly separated between the bodies, and drawn nearer together outside of them.

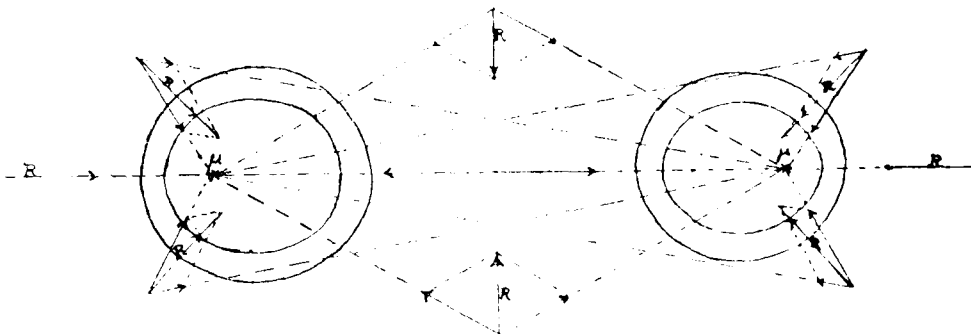

Fig. 16. General theory of the composition of the vectors representing the gravitational forces directed to two equal masses, such as a double star with equal components. It will be noticed that between the masses, the composition largely destroys the oppositely directed separate forces, whereas outside the two masses, the separate forces are but little reduced in composition. The result is that between the bodies the aether is under tension, whereas outside of them it is under increased pressure — both of which tendencies operate to balance the centrifugal force of orbital motion.

3. In general the vector composition gives numerical increase beyond the other body, and numerical decrease between the bodies. Hence we see that:

(α) Between the bodies the successive equipotential surfaces are further apart than they are beyond them.

(β) As the spaces dr indicate the distance we have to traverse for a given change in the force of gravity, which in turn corresponds to a given change in the density of the aether, we perceive that the aether has its density thinned out (or the medium made more homogeneous) between the masses, while the density is somewhat increased beyond them, or rendered more heterogeneous for a given value of dr .

(γ) It thus appears that the waves from each mass operate to expel the aetherons beyond the other mass; so that the medium is put under tension between the bodies, and experiences increase of pressure beyond them.

(δ) The kinetic state of the aether is therefore similar to that of the air under acoustic attraction — there is tension between and increased pressure beyond, which thus generates the central force for holding the planets in their orbits.

(ϵ) In closing this discussion it seems well to record a sagacious remark on gravitation by the late Professor S. W. Burnham, the celebrated discoverer of double stars. It is recalled that the apparent orbit of a binary is an ellipse, and that the radius vector sweeps over equal areas in equal times, as in the case of *Kepler's* law for the planets, which shows that the force is central. It is pointed out that one binary, α Comae Berenices, revolves in a plane passing through the sun; and another binary, γ Virginis, has an inclination so small that it may be taken to be zero, so that the real orbit practically coincides with the apparent orbit which we observe; and in this case the central star is in the focus of the ellipse as required by the *Newtonian* law (fig. 18, tab. 9).

(ζ) When such criteria for motion in a plane under central forces directed to the focus of the ellipse were not sufficient to convince an astronomer who visited his office, in 1894, that the law of gravitation is really universal, and he insisted that further proof was desirable — though *Newton* had not required it for the solar system — Professor *Burnham* remarked: »When equal areas are described in equal times, by the radius vector, so that the forces are known to be central, and directed to

the focus of the ellipse, is not the discussion about the universality of the law of gravitation like debating whether π , the ratio of the circumference to the diameter of a circle, is the same in Jupiter as it is here?«

(η) This suggested debate was enough to settle the question then and there; and it was agreed that the central force which governs the motions of double stars in their elliptic orbits can be nothing but universal gravitation.

Burnham was remarkable for his practical turn of mind, and for the depth of his understanding of the *Newtonian* natural philosophy, which is especially emphasized in the first and second rules of reasoning:

I. »We are to admit no more causes of natural things than such as are both true and sufficient to explain their appearances.«

II. »Therefore to the same natural effects we must, as far as possible, assign the same causes.«

In the sagacious natural philosophy of *Newton* the phenomenon of refraction is viewed as a simple physical problem, and does not lead to the discussion of such vague and chimerical doctrines as the curvature of space, time-space-manifolds, etc.

9. Rigorous Geometric Analysis confirms the Tension in the Aether between two Stars and increased Stress beyond them, and thus incontestably establishes the Cause of Universal Gravitation.

(i) Geometrical composition of the attraction to two centres from any point in space rigorously confirms the theory of tension between the stars and the increase of stress or pressure beyond them.

1. Imagine the two stars to be distant r and r' from any point p in space, and let the angle between r and r' be θ . Then by a well known theorem

$$\cos \theta = (xx' + yy' + zz')/rr' \tag{30}$$

the origin of coordinates being at the point p .

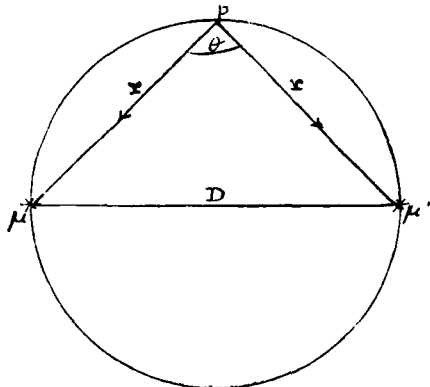

Fig. 17. Geometrical composition of the attraction to two centres investigated, and simplified for points on the circumference of a circle having the two bodies at the extremities of a diameter.

2. If the point p be on the circumference of a circle, having the distance D between the centres of the stars as diameter, the angle θ will be a right angle, and $\cos \theta = 0$. But this condition is special and in general will not hold. If p be beyond the circumference described on D as diameter, $\theta < \pi/2$; if within the circumference, $\theta > \pi/2$.

3. Now whatever be the position of p , we may always compound the attractive forces directed to the two centres according to the parallelogram of forces. Let the two forces be k^2/r^2 , and k'^2/r'^2 ; then by the theorem of the parallelogram we have for the resultant R :

$$R^2 = (k/r)^4 + (k'/r')^4 + 2(k/r)^2 (k'/r')^2 \cos \theta \tag{31}$$

$$R = \sqrt{(k/r)^4 + (k'/r')^4 + 2(k/r)^2 (k'/r')^2 \cos \theta} \tag{32}$$

4. The angular direction of the resultant will always pass between the two stars. And if $\theta = \alpha + \beta$, the two angles α and β may easily be computed when the magnitude and direction of the forces which make up the two sides, $(k/r)^2$ and $(k'/r')^2$ are given, by the formula

$$\sin \alpha : \sin \beta = (k'/r')^2 : (k/r)^2 \tag{33}$$

These forces may be calculated for any point p distant r and r' from the two stars of masses m and m' , or km and $k'm'$, where k is the *Gaussian* constant.

5. In the case of two equal stars the positions between μ and μ , within the above circle, make the resultant R less than $\sqrt{(k/r)^4 + (k'/r')^4}$, because $\cos \theta$ is negative. For positions outside the above circle, the resultant is relatively larger, because $\cos \theta$ is positive, $\theta < \pi/2$. It attains the maximum relative value in the region outside the two stars, on the line $\mu\mu$ prolonged; and the minimum relative value between the two stars, on the line $\mu\mu = D$. This is obvious geometrically from the above figure.

6. The general theory of the composition of forces here set forth shows that the aether is under tension between the two stars, where the geometrical composition tends to a minimum relative value of R . Beyond the two stars, the geometrical composition of forces tends to a relative maximum, and there is greatest increase in the stress of the aether.

The analysis here given explains rigorously the arrangement of the equipotential surfaces about the two equal stars μ and μ . The above figure shows that the minimum distances between the surfaces are outside the stars, where the stress is increased; and maximum distances are between the stars, where the tension is developed, and the density of the aether increases slowly as we go outward from either star as a centre.

(ii) Tension between two stars and increase of stress beyond them the only possible explanation of gravitation.

1. The law of centrifugal force shows that physically there ought to be tension in the aether between two revolving stars; for the centrifugal force actually is overcome and balanced, which can be done most effectively by tension between, and increase of stress or pressure beyond.

2. By no possibility can a pair of stars revolve without some physical agency operating to give tension between them, so that the stresses in the medium balance the centrifugal force. And we may compute the enormous tension required, in terms of the breaking strength of immense cables of steel, (cf. AN 5044, p. 51).

3. Now the equipotential surfaces show the effects of tension in the aether, since the surfaces are symmetrical in all directions about a single spherical mass, but pulled further apart between two spherical bodies. This distortion of the equipotential surfaces, — which are drawn to correspond to equal changes in the force of gravity, — cannot be explained except on the theory of tension, which gives the aether less increase of density between, for given values of dr , and thus puts the successive surfaces further apart.

4. Since mechanical necessity, calculated from the theory of centrifugal force, thus agrees with the facts of observation in regard to the actual positions of the surfaces, it follows that the cause of the observed distorted form of the surfaces must be tension or stretching of the medium. No other possible cause except tension or pulling, which thins out the aether and makes it tend to contract with stupendous power, will explain the known facts.

5. If we knew the observed forms of the surfaces we could from them predict the tension which yields such dis-

tortion; if we knew the mechanical power of the centrifugal force we could predict the distortion of the equipotential surfaces required to balance the stresses exerted. Both conditions lead to the same result, and no other is possible.

6. If we did not know that the density of the aether increases as we go out from a centre like the sun, we should have to discover it before we could form a correct theory of the equipotential surfaces. Thus the distortion of the surfaces shows the heterogeneity of the aether. And as all known facts are thus reconciled, it follows that no other possible theory of the aether can reconcile the facts of observation except the law for increase of density as we recede from the centre $\sigma = \nu r$, which Sir *Isaac Newton* suspected in 1721, but could not establish to his satisfaction.

7. If we did not suspect the unsymmetrical wave-fields about the separate masses, and we were required to assign an adequate cause for the increased distances of the surfaces between the two masses, we should have to conclude:

(a) Between the bodies the equipotential surfaces are relatively separated, by the presence of the second mass.

(b) Beyond either mass the equipotential surfaces are relatively drawn nearer together.

(c) These effects are as if they depended on geometrical stresses superposed, but oppositely directed; thus on the plane yz normal to the line $\mu\mu$, and $\mu\mu$ prolonged, we have:

$$W = P + P' = \iint \omega_s dy dz + \iint \omega'_s dy dz \quad (34)$$

without the masses;

$$W = P - P' = \iint \omega_s dy dz - \iint \omega'_s dy dz \quad (35)$$

between the masses.

8. Therefore, we perceive that the increased distance of the concentric surfaces between the masses, means that we must go a greater distance for a given change in W . Now the aether density increases as we go outward, for a single mass; and in the case of two masses the increase between them is less rapid for given dr , but relatively more rapid externally for both bodies. Hence between the bodies the aether is thinned out by the proximity of the two masses pulling in opposite directions. It is thus under tension, incident to this thinning out. And as the increase in σ is gradual but slower than usual with dr , the concentric surfaces are further apart. In general their figure depends on the masses of the two bodies, whose stresses are here combined.

(iii) Close analogy between density of matter in the earth's crust under isostasy, and density of aether between equipotential surfaces.

(α) In the theory of the equilibrium of the earth's crust, the modern doctrine of isostasy plays a prominent part. If we imagine a solid conical angle $d\omega$, which may be generated by revolving a radius about a fixed small circle, in the surface of a sphere of radius $r = \sqrt{(x^2 + y^2 + z^2)}$, at constant distance from the centre, the principal theorem of isostasy reduces to the expressions:

$$\begin{aligned} dm &= d\omega \int_r^{r+dr} \int_{\theta}^{\theta+d\theta} \int_{\Phi}^{\Phi+d\Phi} \sigma r^2 \sin \theta dr d\theta d\Phi \\ &= d\omega \int_r^{r'+dr'} \int_{\theta}^{\theta'+d\theta'} \int_{\Phi}^{\Phi'+d\Phi'} \sigma' r'^2 \sin \theta' dr' d\theta' d\Phi' \quad (36) \end{aligned}$$

the elementary solid angle $d\omega$ of the two cones of matter extending to the centre of the earth being the same in any two elements, $dm = dm'$, between the limits of the radius r to $r+dr$ and r' to $r'+dr'$, corresponding to the depth of isostatic compensation.

(β) This theorem was first proposed by *Pratt* about 1850, to account for certain apparent anomalies in the attraction of mountains and plateaus in India, but it has now had extensive use in the researches made by *Hayford* for the U. S. Coast and Geodetic Survey, in respect to the continental mass of the United States, and in *Helmert's* geodetic researches as applied to various parts of our globe. Thus it is well established that isostasy is approximately a fact of observation, and to the depth of isostatic compensation $dm = dm'$. *Hayford* found this depth about 76 miles for the continental United States.

(γ) We shall now show that a perfectly analogous theorem holds for the mass of the aether between any two concentric equipotential surfaces drawn about any centre, even when the figures of the equipotential surfaces are disturbed by a neighboring body, as in the case above discussed of two equal stars, with the surfaces distorted between them.

(δ) Thus let $d\omega$ denote the elementary solid angle arbitrarily fixed upon. Then, as in the above integrals, we have:

$$\begin{aligned} dm &= d\omega \int_r^{r+dr} \int_{\theta}^{\theta+d\theta} \int_{\Phi}^{\Phi+d\Phi} \sigma r^2 \sin \theta dr d\theta d\Phi \\ &= dm' = d\omega \int_r^{r'+dr'} \int_{\theta}^{\theta'+d\theta'} \int_{\Phi}^{\Phi'+d\Phi'} \sigma' r'^2 \sin \theta' dr' d\theta' d\Phi'. \quad (37) \end{aligned}$$

(ϵ) For we see that when the equipotential surfaces are further apart than usual it means that there is less rapid increase in the density of the aether as we go outward from the centre. In this case the density of the aether increases as we go outward, but least rapidly towards the other body, where the surfaces are farthest apart. In the case of the earth's crust, on the other hand, the density of the matter increases as we go downward, but least rapidly under the mountains and plateaus, owing to the puffing up or intumescence, as Sir *John Herschel* calls it, of the matter just beneath the crust.

(ζ) Accordingly, it appears that we have a theorem for the aether density quite analogous to that for isostasy in the crust of the globe, but mathematically much more rigorously exact than that of isostasy. The aether theorem

$$\begin{aligned} d\omega \int_r^{r+dr} \int_{\theta}^{\theta+d\theta} \int_{\Phi}^{\Phi+d\Phi} \sigma r^2 \sin \theta dr d\theta d\Phi &= \\ = d\omega \int_r^{r'+dr'} \int_{\theta}^{\theta'+d\theta'} \int_{\Phi}^{\Phi'+d\Phi'} \sigma' r'^2 \sin \theta' dr' d\theta' d\Phi' \quad (38) \end{aligned}$$

obviously fulfills rigorously the conservation of energy, since it applies to the aether in the conical space $d\omega$ between two equipotential surfaces concentric about a fixed centre of mass

$$\mu = \iiint \rho dx dy dz \quad (39)$$

yet disturbed by the aether stresses due to another mass

T. J. J. See. New Theory of the Aether.

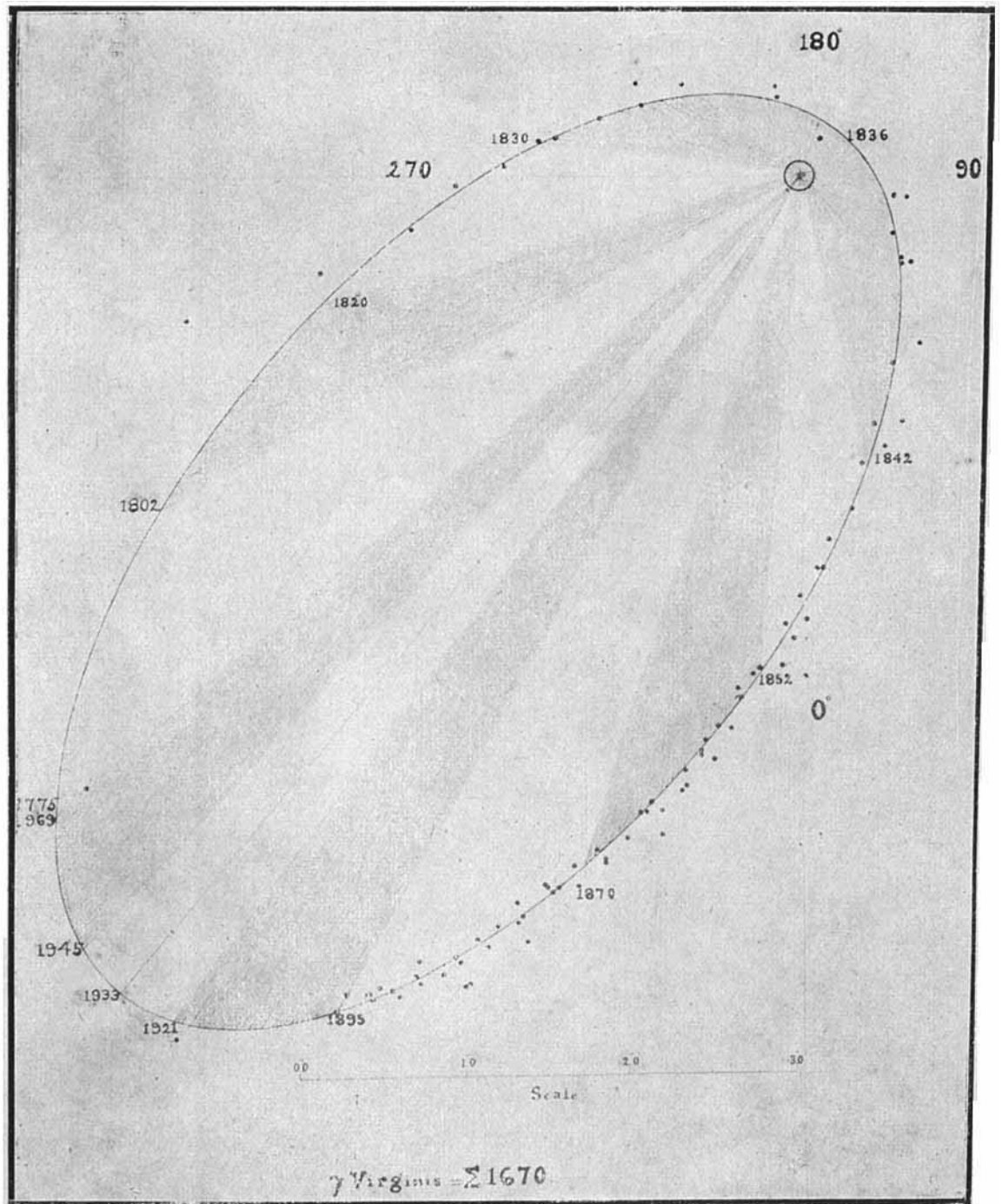

Fig. 18. Geometrical illustrations of the operation of *Kepler's* law of equal areas in equal times for the ellipse, parabola, hyperbola — in which conic sections alone planets and comets may move under the force of gravitation directed to the sun in the focus. On the right, the orbit of γ Virginis, which illustrates *Kepler's* law of areas among the double stars.

$$\mu' = \iiint e' dx' dy' dz'. \quad (40)$$

(η) This formulation of the theorem for the rigorous conservation of energy in the aether makes the conclusion incontestable that the aether is under tension between the masses. The increase of stress or pressure beyond the masses, with more rapidly changing density, is equally obvious, since in these parts the space $d\tau$ required to be traversed is so very small.

(iv) Conclusions drawn from the application of the *Kepler-Newton* method.

The final question now arises: Does not the form of the equipotential surfaces point straight to the cause of gravitation? Is any other interpretation than the one we have given really possible? Obviously not! We have here a criterion which may be applied point by point to the surfaces; and as the surfaces here drawn are found by calculation from the law of gravitation, without regard to the cause involved, yet there is everywhere exact coincidence of the observed facts with the requirements of the wave-theory, it follows exactly as in the *Kepler-Newton* method that one and only one conclusion is possible — namely: gravitation is due to wave-action receding from the two bodies μ and μ' .

Accordingly, just as *Kepler's* laws made the rigorous deductions of *Newton* possible, — providing for the necessary and sufficient conditions of valid reasoning, — so also the form and arrangement of the equipotential surfaces about a single spherical mass, and about a pair of equal spherical masses, considered in connection with the spherical expansion of waves in free space, leads incontestably to the cause of universal gravitation. The argument is based on rigorous geometrical criteria, combined with observed physical facts of wave expansion, and it affords the necessary and sufficient conditions to show that this cause and no other can underlie universal gravitation.

In conclusion, it only remains to add that just as *Kepler's* laws, deduced from *Tycho's* observations of the planets, lead inevitably to the *Newtonian* law of gravitation, — so also the observed law of attraction thus found by *Newton* leads incontestably to waves in the aether as the cause of universal gravitation. In the *Principia*, 1686, *Newton* resolves the several attractive forces separately, at whatever distance the bodies are situated, — thus implying that the forces from the bodies of one system penetrate through the bodies of any other neighboring system, — as if the influence were due to waves in the free aether, capable of freely penetrating all parts of space.

In the remarks following the third rule of reasoning in philosophy, *Newton* says (*Principia*, Lib. III):

»Lastly, if it universally appears, by experiments and astronomical observations, that all bodies about the earth gravitate towards the earth, and that in proportion to the quantity of matter which they severally contain; that the moon likewise, according to the quantity of its matter, gravitates towards the earth; that on the other hand, our sea gravitates towards the moon; and all the planets mutually one towards another; and the comets in like manner towards the sun; we must, in consequence of this rule, universally allow that all

bodies whatsoever are endowed with a principle of mutual gravitation.«

Again, in the General Scholium to the *Principia*, (1713), *Newton* adds:

»Hitherto we have explained the phenomena of the heavens and of our sea by the power of gravity, but have not yet assigned the cause of this power. This is certain, that it must proceed from a cause that penetrates to the very centres of the sun and planets, without suffering the least diminution of its force; that operates not according to the quantity of the surfaces of the particles upon which it acts (as mechanical causes use to do), but according to the quantity of the solid matter which they contain, and propagates its virtue on all sides to immense distances, decreasing always in the duplicate proportion of the distances. Gravitation towards the sun is made up out of the gravitations towards the several particles of which the body of the sun is composed; and in receding from the sun decreases accurately in the duplicate proportion of the distances as far as the orb of saturn, as evidently appears from the quiescence of the aphelia of the planets; nay, and even to the remotest aphelia of the comets, if those aphelia are also quiescent. But hitherto I have not been able to discover the cause of these properties of gravity from phenomena, and I frame no hypotheses; for whatever is not deduced from the phenomena is to be called an hypothesis; and hypotheses, whether metaphysical or physical, whether of occult qualities or mechanical, have no place in experimental philosophy. In this philosophy particular propositions are inferred from the phenomena, and afterwards rendered general by induction. Thus it was that the impenetrability, the mobility, and the impulsive force of bodies, and the laws of motion and of gravitation, were discovered. And to us it is enough that gravity does really exist, and act according to the laws which we have explained, and abundantly serves to account for all the motions of the celestial bodies, and of our sea.«

The great penetrating power of gravitation here pointed out, would be naturally explained by the excessive smallness of the aetheron, 1:3620 of the diameter of a hydrogen molecule, and its high velocity, 471000kms. per second; so that even waves in the aether, if moderately long, could penetrate to the very centres of the sun and planets, as *Newton* says is true of gravitation. *Newton* here expressly declares his inability to discover the cause of gravitation; yet in the authentic Account of Sir *Isaac Newton's* philosophical discoveries, published by his pupil *Colin Maclaurin*, London, 1748, we learn (p. 111):

»He (*Newton*) has plainly signified that he thought that those powers arose from the impulses of a subtile aetherial medium that is diffused over the universe, and penetrates the pores of grosser bodies. It appears from his letters to Mr. *Boyle*, that this was his opinion early; and if he did not publish it sooner, it proceeded from hence only, that he found he was not able, from experiment and observation, to give a satisfactory account of this medium, and the manner of its operation, in producing the chief phenomena of nature.«

The impulses of the aetherial medium imagined by *Newton* to be the cause of gravitation are now explained by

wave-action, in accordance with the kinetic theory, which *Newton* had somewhat developed two centuries ago, in the last edition of his *Optics*, 1721. Thus, in the New theory of the aether, and the Electr. wave-theory of phys. forc., we have merely striven to complete the unfinished labors of Sir *Isaac Newton*.

10. Summary of the Chief Results of the New Theory of the Aether.

(i) Although 245 years had elapsed since *Roemer's* discovery of the velocity of light, 1675, a valid theory of the mechanism underlying this enormous velocity was not available until the appearance of the new kinetic theory of the aether, which treats this medium as a monatomic gas, with mean velocity of the aetheron, $\bar{v} = 1/2\pi \cdot V$.

In the first paper, (AN 5044), we have pointed out the valid grounds on which the new kinetic theory of the aether mainly rests; and subsequently somewhat strengthened, in the first section of the third paper, (AN 5079), the foundations of this remarkable theory. It is undeniable that all the indications of nature point to a kinetic theory of the aether. And now that it is developed, any other view than that set forth would strike us as too improbable to be given serious consideration.

It can scarcely fail to impress natural philosophers that sound is found by experiment to travel four times faster in hydrogen than in oxygen. And when we connect this relatively rapid speed of sound in hydrogen with the square root of the reciprocal of its relative density, — the density being 16 times less than that of oxygen, — we perceive that the dynamical basis of the high wave velocity in hydrogen results from the *Newtonian* formula:

$$V = V(E/\sigma). \tag{41}$$

This formula at once explains why the speed ought to be four times less in oxygen than in hydrogen, since the density σ occurs in the divisor of the right member under the radical.

Proceeding on the basis of these dependable experiments, which are confirmed by researches on many gases, we necessarily are led to ascribe the high velocity of waves of light and electrodynamic action to the excessively small density of the aether. For if the waves of sound in hydrogen so greatly outrun similar waves in oxygen, owing to the 16-fold greater density of oxygen, it follows that for waves of aether to have a large velocity, the aether must have an excessively small density.

From this conclusion there appears to be absolutely no escape. For the experiments on the velocity of sound in gases are essentially very accurate, and the data well determined, with an excessively small if not insensible uncertainty in the observed results. The ratio of the observed velocity of sound in hydrogen to that in oxygen, with their relative densities, thus becomes of the highest significance, and leads directly to the most fundamental laws of wave phenomena in nature.

In very much the same way, we have found the velocity of light to be 217839 times greater than that of sound in theoretical monatomic hydrogen, (AN 5079), whence it follows that the absolute density of the aether at the earth's surface is

$$\sigma = 1888.15 \cdot 10^{-18}. \tag{42}$$

Accordingly in the third paper, AN 5079, a general method is given for finding the density of the aether at any

point of space, where the absolute or relative force of gravity is known compared to that at the earth's surface.

In view of the considerations here cited it will be obvious that the first step in a valid theory of the aether is to give an explanation of the enormous velocity of wave propagation. No theory except the kinetic theory of the aether, in which the aetherons obey the law:

$$\bar{v} = 1/2\pi V \tag{43}$$

will be adequate to explain the enormous velocity of the wave movement.

In the first and third papers, AN 5044, 5079, we have shown that the above law holds for the following gases, when reduced to a monatomic condition:

- | | |
|--------------------------|----------------------------|
| 1. Air | 4. Carbon dioxide, CO_2 |
| 2. Hydrogen | 5. Oxygen |
| 3. Carbon monoxide, CO | 6. Nitrous oxide, N_2O . |
- (44)

The kinetic theory of the aether must therefore be regarded as well established. Observation indicates that in a monatomic gas the above formula is accurately fulfilled; and as the aether is not known to be capable of any combinations we naturally take its aetheron to have the property of a monatomic gas.

In view of the simplicity and directness of these considerations, it appears to be truly remarkable that nearly two and a half centuries should elapse between *Roemer's* discovery of the velocity of light, and the development of a kinetic theory of this wave-motion, 1920. It must be fairly obvious to natural philosophers that the foremost problem of the aether is the explanation of the enormous velocity of light. And as electrodynamic action and waves in radio-telegraphy take place with the same velocity, the underlying rapid motion of the aetheron is of the deepest interest, and will have the widest applications in all branches of physical science.

(ii) *Einstein* assigns no cause of gravitation, and as he rejects the aether, which is required for conveying stresses across space, his general theory of relativity is misleading.

In the first paper on the new theory of the aether we have explained that *Einstein* rejects the aether entirely. *Michelson* and other eminent authorities have remarked on the inadmissibility of this procedure; and not a few experienced investigators have rejected *Einstein's* general theory of relativity because he has no medium for conveying light, heat and natural forces across space.

The arguments of *Michelson* and others drawn from the theory of light are quite unanswerable. Yet it may be worth while to inquire why, if there be no aether, light and electric waves are transmitted across space with the velocity of $V = 3 \cdot 10^{10}$ cms. If there be no aethereal medium of small density and great elasticity, it would be much more logical to assume that action at a distance is instantaneous. Yet this is contrary to observation.

And although *Einstein* assumes as the basis of his system that »nothing travels faster than light«, he nowhere explains why light should have a finite instead of an infinite velocity.

The wave-theory, on the other hand, lays down no dogma whatever. It takes light and electric waves to travel with the observed velocity, $V = 3 \cdot 10^{10}$ cms., and then inquires what is the mean velocity of the aetheron. By the well established

facts of the kinetic theory of gases, this remarkable theorem is deduced for the aether:

$$\bar{v} = \frac{1}{2}\pi V = 1.57 \cdot 3 \cdot 10^{10} \text{ cms} = 471239 \text{ kms} \quad (45)$$

where V is the wave velocity, and \bar{v} the mean velocity of the aetheron.

It is found that the aetheron moves 10000 times faster than our swiftest planets, and for bodies moving with uniform velocity, as in orbits essentially circular, offers no resistance whatever to the motions of the planets. This corresponds to the known facts of the solar system, which gives no indication of aethereal resistance to the motions of the planets and satellites. If the orbits are sensibly elliptical, there will be alternate acceleration and retardation, but the effect is very slight and in fact insensible to observation.

When two bodies which are magnetic are in relative motion, there is an inductive effect, owing to the change in the wave fields; and this is observed in the earth's magnetism, and found to depend on the sun and moon, as first noted by *Kreil* at Prague, 1841, and afterwards independently discovered by *John Allen Broun*, 1845.

The existence of a semi-diurnal tide in the earth's magnetism obeying the law of the inverse cube of the distance of the moon was fully established by *Broun* and confirmed by *Balfour Stewart* and *Airy*, who pointed out that the tide acted along the line from the Red Sea to Hudson's Bay (the magnetic pole). In AN 5079, p. 268, we have shown that *Lloyd* misinterpreted his equations, in 1858, and the error has been repeated in many later writers. *Lloyd* retained in his analysis of 1858 the angle θ instead of the angle 2θ used in the tide-generating potential. All the phenomena of the earth's magnetism, including the periodicities depending on the heavenly bodies, are fully explained by the wave-theory.

Accordingly, it appears that the wave-theory accounts for the magnetism of the heavenly bodies, and connects cosmical magnetism with universal gravitation, which no previous theory has been able to do.

Einstein's theory, on the other hand, gives no such connection. In fact as *Einstein* even proposed to do away with the aether, he has no mechanism for conveying action across space. Just how empty space is to be conceived as capable of transmitting forces equivalent to the breaking strength of millions of immense cables of steel is not apparent.

Accordingly it is recognized that *Einstein's* reasoning is totally devoid of physical basis. He treats his problem as if it related to pure mathematics, and as if his reasoning were not required to conform to recognized physical conditions. And since he even introduces the curvature of space, to explain a mere phenomenon of refraction, which *Newton* would not have sanctioned, we perceive that the doctrines of *Einstein* are chiefly remarkable for the lack of understanding of the physical universe which they display.

The kinetic theory of the aether perfectly accounts for the phenomenon of aberration, the *Michelson-Morley* experiment, the motion of the perihelion of Mercury, and all other phenomena treated of in the theory of relativity. Accordingly, *Einstein's* theory of relativity is as superfluous as it is misleading. In all his speculations there is not one truth corresponding to the actual phenomena of nature.

(iii) Final table of the physical constants of the aether.

In the course of the development of the new theory of the aether we have been led to a few changes, but the table of constants of the aether given in AN 5044, p. 65-66, still remains essentially correct, except as indicated below.

1. The method for calculating the density of the aether from the constant of solar radiation devised by Lord *Kelvin* in 1854, and modernized in AN 5044, p. 63-64, is now recognized to be defective, owing to the decrease of density of the aether near the earth. For reasons indicated in AN 5079, p. 233-239, we must first find the density of the aether at the earth's surface, and then calculate the density at the surface of the sun and planets, by the processes explained on p. 236-237.

At the earth's surface the density of the aether is found to be

$$\sigma_{3s} = 1888.15 \cdot 10^{-18} \quad (46)$$

while at the sun's surface the density is

$$\sigma_{0s} = (1888.15 \cdot 10^{-18} / 219) 41.4868 = 357.6865 \cdot 10^{-18}. \quad (47)$$

Accordingly, the density of the aether at the earth's surface is 4.31 times that given by *Kelvin's* modified method, while at the surface of the sun the density is about 178.84 times that deduced from *Kelvin's* method. We now recognize that *Kelvin's* method is defective and the results given in the first paper, p. 64, are to be superseded by the method for finding the absolute density outlined in AN 5079, p. 236.

2. In the first paper the ratio of amplitude to wave-length was assumed to be $A/\lambda = 1/101.23$, whereas in the fourth paper, AN 5085, it was found to be $A/\lambda = 1:1660508000$ which is equivalent to

$$A/\lambda = 1/101.23 \cdot 1/163045 \quad (48)$$

or over 163000 times smaller than the value first used, which accorded with the experienced judgement of *Kelvin*, *Maxwell* and *Larmor*. Accordingly

$$Ap = 2\pi/101.23 \cdot 1/163045 = 0.0000003806827; \\ \log(Ap) = 3.5805632_{-10}. \quad (49)$$

3. The energy per cubic centimetre at the sun's surface is small, owing to the small density of the aether, and the small value of Ap , where $Ap = 2\pi A/\lambda$, and A/λ is the ratio of the amplitude to the wave-length. The formula for the kinetic energy

$$E = (0.63662) \sigma V^2 (Ap)^2 \\ = (0.63662) (357.6865 \cdot 10^{-18}) (3 \cdot 10^{10})^2 (0.0000003806827) \\ = 0.0000002968587 \text{ ergs.} \quad (50)$$

This value of the energy at the sun's surface seems very insignificant compared to the value 4.41455 ergs, calculated in the first paper, AN 5044, p. 64; but it follows from the change in density, and above all, the very small amplitude just discussed above, in paragraph 1. Accordingly, great as the changes in our old conceptions are, we believe this new result to be valid, and entitled to adoption in our final results.

4. Greatest tangential stress per square centimetre at the sun's surface: $\sigma V^2 (Ap) = 0.12252$ dynes. (51)

This value likewise is very small compared to the value 111.1713 dynes found in AN 5044, p. 64; but, as before, the difference is explained by the change in the density and

ratio of amplitude to wave-length, which latter factor is decreased by the divisor 163054.

5. Coefficient of rigidity (or viscosity) of the aether by the formula:

$$\kappa = \sigma V^2 = (357.6865 \cdot 10^{-18})(3 \cdot 10^{10})^2 \quad (52)$$

yields

$$\kappa_{os} = 321917.8 \text{ at the sun's surface} \quad (53)$$

$$\kappa_{3e} = 7050000 \text{ at the earth's surface.} \quad (54)$$

The rigidity of the aether thus turns out to be much larger than the values found in AN 5044, p. 64, which was only 1800.

6. Density of the aether at the sun's surface:

$$\sigma_{os} = 357.6865 \cdot 10^{-18}. \quad (55)$$

7. At the earth's surface the density of the aether is found to be

$$\sigma_{3e} = 1888.15 \cdot 10^{-18}. \quad (56)$$

At the surfaces of the other planets the absolute densities are as given in the table, in AN 5079, pp. 237-238.

8. Mean velocity of the aetheron

$$\bar{v} = 1.57 V = 47123900000 \text{ cms.} \quad (57)$$

9. The molecular weight of the aetheron, calculated by *Maxwell's* theorem on the equality of the kinetic energies in all gases

$$\frac{1}{2} m v^2 = \frac{1}{2} m' v'^2 \quad (58)$$

$$w = 12.92 \cdot 10^{-12}, (H = 1). \quad (59)$$

10. Average length of the mean free path, at the sun's surface or at the earth's surface:

$$l = 3\kappa_{os}/\sigma\bar{v} = 3\sigma V^2/\sigma\bar{v} = 3V^2/\bar{v} = 57295900000 \text{ cms} \quad (60)$$

the same as in AN 5044, p. 66.

11. Number of corpuscular collisions per second at the sun's surface = $\bar{v}/l = 0.82$, as in AN 5044, p. 66. (61)

12. According to *Avogadro's* law equal volumes of all gases under the same conditions contain an equal number of molecules. And as hydrogen is 47453880000 times denser than aether, we may equate the masses of two spherical molecules thus:

$$\frac{4}{3}\pi\sigma r^3 = 47453880000 \frac{4}{3}\pi\sigma' r'^3. \quad (62)$$

And if we take the internal densities of the two molecules to be equal, $\sigma = \sigma'$, we have

$$r = \sqrt[3]{47453880000} \cdot r' = 3620.405 \cdot r' \quad (63)$$

that is, the hydrogen molecule has 3620 times greater radius than the aetheron.

We may form a very useful picture of these relative sizes by imagining the hydrogen molecule magnified to the size of the earth, with mean radius $r = 6370.5$ kms. On this scale the aetheron will have a radius of 1.7596 kms, or 1.0934 miles.

Accordingly, if the earth represents a hydrogen molecule, a spherical mountain a little over two miles in diameter (more exactly 11500 feet) would represent an aetheron. This is very nearly the height of Mt. Aetna (10872); but as the base of this volcano is very much extended, we must consider the aetheron to correspond only to the central part of the cone, about a mile in radius.

Table for comparing the physical properties of the aether with well known terrestrial gases.

Gas	Mean velocity of molecule	Molecular wt. (H=1)	Coefficient of viscosity κ at 0° C.	Mean free path $l = 3\kappa/\sigma\bar{v}$	Collisions per second $c = \bar{v}/l$ - 8 percent, for collision rebound	Radii of molecules calculated by four independent processes, except in the case of the aether ($= 1/3620$ of H)
Aether	47123900000 cms	$12.92 \cdot 10^{-12}$	7050000	57295900000 cms	0.82	$3.701 \cdot 10^{-12}$
Air	49800 »	14.43	0.0001724	0.0000059 »	$7765 \cdot 10^6$	$1.86 \cdot 10^{-8}$
Hydrogen	185900 »	1	0.0000867	0.0000116 »	$14743 \cdot 10^6$	$1.34 \cdot 10^{-8}$
Helium	132113 »	1.98	0.0001889	0.0000171 »	$7108 \cdot 10^6$	$1.11 \cdot 10^{-8}$
Oxygen	46100 »	16	0.0001896	0.0000063 »	$6732 \cdot 10^6$	$1.81 \cdot 10^{-8}$
Nitrogen	49200 »	14	0.0001660	0.0000057 »	$7941 \cdot 10^6$	$1.90 \cdot 10^{-8}$
Argon	41527 »	19.96	0.000210	0.0000063 »	$6064 \cdot 10^6$	$1.81 \cdot 10^{-8}$
CO	49700 »	14	0.0001626	0.0000058 »	$7901 \cdot 10^6$	$1.88 \cdot 10^{-8}$
CO ₂	39600 »	22	0.0001410	0.0000040 »	$9108 \cdot 10^6$	$2.28 \cdot 10^{-8}$
Chlorine	31262 »	35.36	0.0001287	0.0000029 »	$9874 \cdot 10^6$	$2.68 \cdot 10^{-8}$
Steam H ₂ O	62000 »	9	0.0000912	0.0000040 »	$14260 \cdot 10^6$	$2.27 \cdot 10^{-8}$

11. The Central Forces of Planetary Motion explained by the Wave-Theory.

(i) In the problem of gravitation the force is central, and equal areas are described in equal times.

1. The celebrated laws discovered by *Kepler*, 1609, 1618, — that the paths of the planets are ellipses, with the sun in their foci; and that the radii vectores of any planet describe equal areas in equal times; and finally, that the squares of their periodic times are as the cubes of the mean distances or major axes — led *Newton* to the law of universal gravitation:

$$f = k^2 m m' / r^2. \quad (64)$$

Kepler's law that the radius vector describes equal areas in equal times is illustrated by the geometrical figures on

plate 9, for the ellipse, parabola, and hyperbola, and thus applies alike to planets and comets, and also to the double stars.

2. Since it is a fact, that under a central force varying according to any law of distance, equal areas will be described in equal times, *Newton* correctly concluded that the planets and comets are drawn to the centre of the sun by powerful central forces. And *Sir Isaac Newton* demonstrated that, with the sun in the focus of the conic section, the law would be that of the inverse squares given above, since shown to hold true in all the actions of universal gravitation.

3. It is well known that *Huyghens*, *Hooke*, *Wren*, *Newton* and *Halley* were practical investigators and experimenters, and thus had very clear ideas on the action of central forces.

They recognized fully that curvature of the path of the planet can not take place at every instant of time without the constant action of accelerative forces directed to the focus of the conic section. *Euler, Lagrange, Laplace* and the later illustrious successors of *Newton* have fully confirmed the validity of the *Newtonian* argument; so that no one ever seriously thought of questioning the *Newtonian* dynamics till *Einstein's* misleading speculations began to be developed.

4. Accordingly, the scientific world read with astonishment in the Monthly Notices of the Royal Astronomical Society, (Oct. 1916, 76, p. 702) *De Sitter's* claim that »Gravity is not a force, but a property of space.«

By actual calculations carried out in the first paper we found that the utmost strength of five million million cables of steel, each a foot in diameter, when the steel has the breaking strength of 30 tons to the square inch, are required to curve the path of the moon in its orbit about the earth. And to curve the path of the earth's motion about the sun an eleven inch cable of steel of the same strength, on each square foot of a hemispherical cross section of the earth, would be stretched to its utmost limits by the force of the sun's gravity, constantly acting on our planet for governing its motion. After having made these calculations I had no more doubt that gravity is a real force than had *Wren, Newton* and *Halley* in 1686. As we have shown that the aether has an elasticity 689321600000 times greater than our air in proportion to its density, it is evident from the nature of the triple integral for the potential, that the medium is capable of sustaining these stupendous forces.

5. The action of centrifugal forces in driving bodies from the centre, in the direction of the tangent, and expressed by the formula:

$$f = mv^2/\rho \quad (65)$$

— where v is the velocity and ρ is the radius of curvature — has been fully understood since the time of *Huyghens*, (cf. *De horologio oscillatorio*, 1673) about 250 years ago. As the planets do not recede from the sun, but curve their paths about the centre of the sun, it follows, as *Newton* pointed out, not only that there is a central force incessantly balancing the centrifugal force, but also that it is proportional to mass, and thus gravitation is not a property of space, but of matter, in the focus of the conic section. In the scholium to Proposition IV, Lib. II of the *Principia*, *Newton* says: »By such propositions, Mr. *Huyghens*, in his excellent book, *De horologio oscillatorio*, has compared the force of gravity with the centrifugal forces of the revolving bodies.«

6. In view of the observed phenomena of the heavens it is not possible to depart from this conclusion of *Huyghens* and *Newton*. *Einstein's* theory therefore is unconditionally rejected as wholly contrary to dynamical laws admitting of easy verification. And it remains to consider what other conceptions of gravitation are admissible. We have seen that the gravitational potential introduced by *Laplace*, 1782, has the form:

$$V = M/r = \iiint [(x-x')^2 + (y-y')^2 + (z-z')^2]^{-1/2} \times \sigma dx dy dz. \quad (66)$$

This triple integral corresponds to the summation of the stress in the aether due to the superposition of waves, with amplitude $A = k/r$ from each atom of the attracting mass.

(ii) The geometrical and physical interpretation of the potential leads inevitably to the wave-theory.

We have already pointed out geometrical and physical properties of the medium which lead inevitably to the wave-theory. There is not only evidence of the wave-field about all bodies — whence the forces they exert — but also proof that the wave field travels as the bodies move, and thus carries along the field of force which shows itself near bodies.

1. We conclude therefore that every body has about it an infinitely extended wave field, the amplitudes varying inversely as the distance, $A = k/r$, and the forces inversely as the square of the distances; which corresponds exactly to the known facts of universal gravitation. And since it is shown mathematically that waves in the aether expanding freely in cubical space, would follow the law of amplitude: $A = k/r$, it cannot be accidental that *Laplace's* expression for the potential has this form. On the contrary, it follows that the expression for the potential of gravitation is determined by the amplitudes of the waves receding from each atom; and thus we necessarily are led to the wave-theory of gravitation. For the potential of a mass M is derived from the triple integration of all the elements, $dm = \sigma dx dy dz$, at their appropriate distances, $r = \sqrt{[(x-x')^2 + (y-y')^2 + (z-z')^2]}$; and this corresponds to the amplitude of the wave from any atom, and the mean result to the summation of the stresses due to the separate atoms of the whole mass.

2. Now there must be some simple interpretation of the formula

$$dV = dm/r = [(x-x')^2 + (y-y')^2 + (z-z')^2]^{-1/2} \times \sigma dx dy dz \quad (67)$$

which by integration leads to

$$V = \int dm/r = \iiint [(x-x')^2 + (y-y')^2 + (z-z')^2]^{-1/2} \times \sigma dx dy dz. \quad (68)$$

And as the waves when expanding freely in cubical space follow this same law, the amplitude being $A = k/r$, our interpretation of the potential follows both geometrical and physical laws, and therefore the chances are infinity to one that the wave-theory yields the correct interpretation.

3. The curves for the amplitudes of the waves receding from a centre are as shown in the figure 14, section 8 above. These amplitudes show how the agitation of the waves thins out the density of the medium, towards the centre, and allows it to increase directly as r , so that its final density is inversely as the average wave amplitude, or directly as the distance, which corresponds with the undefined heterogeneity of the aether imagined by *Newton*, 1721.

4. Accordingly, the wave-theory of universal gravitation is indicated by the amplitude of the aether wave freely expanding in cubical space, and by the nature of the observed force of gravitation $f = k^2 m m'/r^2$, which leads to $A = \sqrt{f} = k/r$, or

$$V = M/r = \iiint [(x-x')^2 + (y-y')^2 + (z-z')^2]^{-1/2} \times \sigma dx dy dz. \quad (69)$$

The aether transmits each wave independently of all the rest and the effect of their superposition is a mean state of stress depending on the average wave amplitude, and on the whole mass

$$M = \iiint \sigma dx dy dz \quad (70)$$

which is included under the triple integral in the above formula for the potential.

5. In the fourth paper (AN 5085, p. 448) we have given a diagram of the wave field about a pair of equal stars (reproduced on a larger scale in fig. 19 on plate 10), and shown that at the boundary of the concentric ellipsoids, the whole of the wave stress in the aether due to the two stars is directed along the corresponding system of confocal hyperbolas. Accordingly, if in the diagram we imagine the density of the aether to decrease asymptotically as the two stars are approached, we shall have not only an accurate image of the wave field, but of that stress of the aether towards these centres which is the cause of gravitation. The individual aetherons have a mean velocity $\bar{v} = \frac{1}{2}\pi V = 471239$ kms per second, and thus they press incessantly towards the centres where the density is small, but the amplitude large.

6. It follows therefore that the original conceptions outlined somewhat vaguely by Sir *Isaac Newton* in 1721, but not heretofore considered susceptible of proof, are really true, and now established with all the rigor that may be drawn from modern mathematical and physical research. The law of the wave amplitude about any centre of disturbance admits of verification; and we know that the density of the medium is arranged inversely as the amplitude as the waves recede from that centre. And that such waves do recede from bodies is amply shown by the waves of magnetic phenomena, which follow laws of amplitude similar to those of gravitation.

(iii) The wave-theory of acoustic attraction and repulsion shows that in the aether also the aetherons are so distributed as to be in kinetic equilibrium, and thus under the rapid motions of the aetherons the aether is of decreased density between two bodies.

In the fifth paper on the new theory of the aether (AN 5130) we have applied the wave-theory to acoustic attraction and repulsion, which heretofore has not been satisfactorily explained. As sound is a wave phenomenon, and the velocities of transmission in various media well understood, we were enabled to study the progress of the wave-front in air and in balloons filled with carbon dioxide and hydrogen respectively.

In the case of a carbon dioxide balloon, we found that if the waves travel through the air with the velocity 1, the speed through the carbon dioxide will be 0.78 only; and therefore every phase of the wave reaches the opposite side of the balloon through the air in advance of that coming directly through the balloon. The result is a series of advance molecular impulses on the elastic membrane constituting the rear wall of the balloon. The impulses generate slight oscillations in the whole balloon by which a part of the surrounding air thus agitated is transferred gradually to the rear side of the balloon.

As the density of the air is thus decreased on the side next to the source of the sound, and correspondingly increased on the rear side of the balloon, the kinetic equilibrium of the atmospheric medium can only be maintained when the balloon containing CO_2 tends to approach the source of the sound. In other words, the air is worked out somewhat from between the sources of the sound and the balloon, and forced in behind the balloon; so that we have what is called acoustic attraction.

This explanation, without mathematical formulae, is perfectly simple and satisfactory; and we have also treated by the same method, of depicting the progress of the wave-front, the impulses which cause repulsion when the balloon is filled with hydrogen. In this latter case the sound wave travels so fast in hydrogen that it quickly turns its front, and reenters the air on the side next to the source of the sound. Thus repulsion results from accentuation of agitation, the wave motion being so directed that the air is not decreased in elastic pressure on the side next to the source of the sound, but actually increased. The kinetic equilibrium of the atmospheric medium thus requires that the balloon filled with hydrogen be repelled from the source of the sound.

12. The Tension of the Aether is a Maximum along the Right Line connecting the Sun and a Planet, and thus the Wave-Theory conforms to the *Newtonian Theory* of a Central Force directed to the Focus of the Conic Section.

(i) Maximum wave-action in straight lines connecting the bodies μ and μ .

It has long been remarked by eminent philosophers that the chief forces of nature appear to act in straight lines, as along the radius vector drawn from the centre of a planet to the centre of the sun. And the question naturally arises as to why the stresses in the aether should be thus exerted. We shall show that such rectilinear action in minimum paths necessarily happens when waves are transmitted in an elastic medium like the aether.

But before doing so we shall recall from the first paper, AN 5044, p. 51, that in the case of the moon revolving about the earth, the central force required is equivalent to the full breaking strength of 50000000000 cables of steel one foot in diameter, when the steel has the enormous tenacity of 30 tons to the square inch. In case of the earth revolving about the sun, the curvature of the orbit requires the exertion of a central force equivalent to the full breaking strength of an 11-inch cable of steel of the above tenacity on each square foot of a hemispherical cross section of the earth. Thus to hold the earth in its orbit it would be necessary almost to cover the illuminated hemisphere with a solid forest of steel cables.

Now these stupendous forces are sustained by the elastic medium of the aether, and the mere contemplation of the above tension, which must be balanced, shows the absurdity of the views of *Einstein* and *De Sitter* that »gravity is not a force, but a property of space«. (Monthly Notices 76, 1916, p. 702). In the aether, however, the stresses are not confined to the narrow spaces occupied by the above named cables of steel, but are general throughout this medium, the wave motion being directed from the atoms in the sun and the reaction towards the sun's centre.

It follows from the kinetic theory of the aether that each body carries its wave-field with it, without regard to the wave-field carried by any other body. Accordingly, the wave-fields from the two bodies interpenetrate, and in the arrangement of kinetic equilibrium, the aether density thus becomes a minimum in the right line connecting the two bodies, which is the direction of the stress observed in the

planetary forces. For we have seen that towards either body the density decreases; and along the shortest path, or right line connecting the centres of the bodies, the independent thinning out due to the two wave-fields will be a maximum. The density of the aether is therefore a minimum along the line SE , which connects the sun and earth.

We may look at this problem in a slightly different way as follows: the waves from S tend to thin out the aether to a degree $\sigma = \nu r$, at the distance r ; the waves from E on the other hand yield a density $\sigma' = \nu' r'$ at the distance r' from the centre of E . When the lines r and r' lie in the right line SE they represent the shortest possible connection of any third point with the two chief bodies S and E .

Let us imagine a set of rotating axes, as in the restricted problem of the three bodies (Researches on the evolution of the stellar systems, vol. 2, 1910, chap. 8); then the distances from either centre will be, for motion in the plane of xy :

$$r = \sqrt{x^2 + y^2}; \quad r' = \sqrt{(x-1)^2 + y^2}; \quad s = r + r'. \quad (71)$$

Accordingly,

$$\overline{SE^2} = \rho^2 = r^2 + r'^2 - 2rr' \cos(r, r'). \quad (72)$$

And using the above values for r and r' we have:

$$\sigma = \nu r = \nu \sqrt{x^2 + y^2} \quad \sigma' = \nu' r' = \nu' \sqrt{(x-1)^2 + y^2} \quad (73)$$

$$\rho^2 = (\sigma/\nu)^2 + (\sigma'/\nu')^2 - 2(\sigma/\nu)(\sigma'/\nu') \cos(r, r'). \quad (74)$$

Now as SE is a straight line it is the minimum path between the two bodies, and by the equation (73) the minimum density throughout can be fulfilled only when the point $p(x, y)$ lies on the line SE , so that the double integral is a minimum:

$$\begin{aligned} & \delta \iint ds \, d\sigma = \\ & = \delta \iint d\sigma [(\sigma/\nu)^2 + (\sigma'/\nu')^2 - 2(\sigma/\nu)(\sigma'/\nu') \cos(r, r')]^{1/2} = \\ & = \rho \delta \int d\sigma = 0. \end{aligned} \quad (75)$$

For ρ is known to be the minimum path,

$$\delta s = \delta(r+r') = 0 \quad (76)$$

and as σ and σ' increase for any departure of the point $p(x, y)$ from the minimum path ρ corresponding to $\delta s = 0$, it follows from the equation (75) that the condition of minimum for the double integral is

$$\delta \iint ds \, d\sigma = \rho \delta \int d\sigma = 0 \quad (77)$$

which requires the point to lie on the line $SE = \rho$.

The aether therefore has minimum density along the line joining the sun and planet. It is denser on either side of this line, because under the wave actions of the two centres the aetherons are worked out from between the bodies, and increase the pressure or stress beyond them, as correctly held in the Electrodynamical wave-theory of physical forces, vol. 1, 1917.

For two equal masses μ and μ , we have the foregoing figure for the equipotential surfaces:

$$c_i = \mu/r + \mu/r'. \quad (78)$$

And beneath it, for comparison, we have added, in fig. 20, plate 11, the wave-field for two equal stars, thus making a double plate, as explained below. The tendency to form an hour-glass figure, with symmetrical neck between the equal masses is due to the potential or average amplitude of the waves proceeding from either mass. If the masses were unequal,

μ and μ' , where μ'/μ may be any proper fraction whatever, the equation of the surfaces would be:

$$c_i = 1/r + (\mu'/\mu)/r'. \quad (79)$$

And the closed surface around the smaller mass would be contracted in proportion to the size of the mass μ'/μ , but otherwise equipotential surfaces would be of the same general type as the above.

Figure 20 therefore conveys a good impression of the effect of the interpenetration of the wave-fields in decreasing the density of the aether between the masses, and increasing it beyond. Wherever the surfaces are close together there is rapid change in the stress or density; and where they are far apart, there is little change in the density. The change of density is thus least rapid between the bodies where each mass tends to expel some of the aetherons. The result is tremendous tension along the line μ and μ , with increase of pressure where the surfaces are denser, beyond either mass.

Now tension in the medium between the bodies, and increased pressure beyond them is exactly the mechanical action required to give the central attraction for balancing the centrifugal force of revolving bodies. The wave-theory thus corresponds exactly with the phenomena of nature, and it is impossible to doubt the assigned cause of the stupendous forces which hold the planets in their orbits.

These forces are so immense that nothing but a medium of enormous elasticity would be adequate to sustain the required stress. But since the aether has an elasticity 689321600000 times greater than air in proportion to its density, — an elasticity almost infinite — and moreover the triple integral for the potential shows that the stress increases directly as the mass, we see that all required dynamical conditions are fulfilled, and thus the wave-theory assigns the true cause of universal gravitation.

(ii) Final remarks on the new theory of the aether.

The wave-theory as developed in the new theory of the aether has been found adequate to explain all the forces operating in nature. More stress has been laid upon the explanation of some of these forces than upon others, but this is only by way of illuminating the subjects most obscure and heretofore very bewildering to geometers and natural philosophers.

We need not here dwell on the theory of molecular forces — surface tension, capillarity, cohesion, adhesion, etc. — because we have shown that all these phenomena depend on wave-action. And we have even explained the tenacity and hardness of bodies by the wave stresses in the sheath of aether at the boundaries of bodies.

In the same way chemical affinity and vital forces, depending on chemical processes in connection with capillarity, osmosis, etc., are naturally explained by wave-action. The wave-theory is shown to be identical with *Ampère's* theory, proposed about a century ago to account for magnetism, by the hypothesis of elementary electric currents circulating about the atoms.

Now we see all atoms vibrating and emitting waves which are flat in the planes of their equators. And as this simple theory is useful in magnetism, so also in chemical phenomena

and the processes involved in vital forces, all of which depend on chemical action.

As the power of a galvanic battery depends on chemical changes, it is inevitable that chemical affinity and vital forces should be referred to electric action. In the battery there are groups of vibrating atoms acting in concert and thus the changes go on in an oscillatory character and the current carried along a wire is nothing but a series of waves in the aether, resistance of which develops heat and light.

All chemical actions involve changes of temperature, which is another indication of the electric basis of chemical affinity. The support of animal heat by combustion of hydrocarbons with oxygen is another proof of the same proposition.

One of the most beautiful of the investigations of molecular forces relates to the globular figures of liquid drops, which are minimal surfaces, and easily explained by the wave-theory under least action. Nothing could be more wonderful than the results here brought to light; and the power which may be attained by wave-action is impressively illustrated by the new theory of lightning and of explosive forces.

The wave-theory was partially developed about a century ago by the mathematical analysis of *Fourier* and *Poisson*. As now extended and applied to all classes of physical phenomena, it may justly claim the attention of geometers and natural philosophers; so that the modern investigator can understand the remark of *Plato*: ὁ Θεὸς ἀεὶ γεωμετρεῖ.

The conclusion that the Deity always geometrizes is very much like the remark of *Kepler* that, in discovering the geometrical laws of planetary motion, he was only thinking God's thoughts after Him. *Kepler's* researches led to the greatest advance of physical astronomy in his time, and one of the greatest advances of all ages.

In the same way if *Plato's* principle that the Deity always geometrizes — all the forces of nature being due to wave-action, — and geometrical figures such as minimal surfaces therefore resulting from least action of the whole system of waves be applicable to the most varied natural phenomena, as we have endeavoured to show — then we cannot doubt that a great and lasting advance in natural philosophy should follow the development of the wave-theory. The wave-theory will enable the modern geometer to think God's thoughts after Him; for it gives an insight into the true laws of nature, and we are saved from the endless groping in the dark heretofore unavoidable.

Accordingly, we have merely to remark:

1. Waves in the aether following the laws we have explained will account for universal gravitation, — the amplitude $A = k/r$ resulting from unhindered expansion of the waves in free space, and yielding the required law of force established by *Newton*, 1686: $f = A^2 = k^2/r^2$.

2. The planetary paths curve incessantly under the action of central forces equivalent to the breaking strength of millions of immense cables of the strongest steel. There must be a medium called the aether capable of sustaining the immense stresses for holding the planets in their orbits.

3. The aether is shown to have an elasticity 689321600000 times greater than that of air in proportion to its density. And as air alone is observed to be given such rotatory motion and stress in the central path of a cyclone as to exert the most

amazing destructive power over all natural objects, we can easily understand how the power of the aether waves may accumulate near great bodies to any required extent through the mere form of the expression for the potential, the waves from the separate atoms being of average wave amplitude k/r , and the whole of the independent effects being superposed in the triple integral:

$$V = M/r = \iiint [(x-x')^2 + (y-y')^2 + (z-z')^2]^{-1/2} \times \sigma dx dy dz. \quad (80)$$

4. The cause here assigned fulfills the required geometrical laws, and is sufficient to explain the accumulated stress in the aether called gravity. No other explanation of gravitation is known, yet one is so urgently required that *Einstein* has been led to mere mathematical abstractions devoid of physical basis. For he denies the existence of an aethereal medium for sustaining the planetary forces. Thus *Einstein's* speculations are of no value, because contrary to physical experiments, which show that centrifugal motion must be balanced by central tension, if we are to have steady orbital motion of the heavenly bodies.

5. The wave-theory postulates aether stresses depending on each atom, with amplitude appropriate to its distance; and the triple integral sums up these effects at any point of space, so that the gravitational potential fulfills *Laplace's* celebrated differential equation for external space:

$$\partial^2 V/\partial x^2 + \partial^2 V/\partial y^2 + \partial^2 V/\partial z^2 = 0. \quad (81)$$

And for points within the mass *Laplace's* equation becomes *Poisson's* celebrated differential equation:

$$\partial^2 V/\partial x^2 + \partial^2 V/\partial y^2 + \partial^2 V/\partial z^2 = -4\pi\sigma. \quad (82)$$

6. Discontinuity in the wave-phenomena at the boundary is also implied in *Poisson's* equation of wave motion:

$$\partial^2 \Phi/\partial t^2 = a^2 (\partial^2 \Phi/\partial x^2 + \partial^2 \Phi/\partial y^2 + \partial^2 \Phi/\partial z^2) \quad (83)$$

of which the *Fourier-Poisson* solution is:

$$\Phi = \Omega(x, y, z, t) = \iiint \iiint \iiint e^{(A+Bh\lambda)} V^{-1} \cdot \psi_1(\xi, \eta, \zeta) d\xi d\eta d\zeta d\lambda d\mu d\nu. \quad (84)$$

Since the wave-theory rigorously fulfills all geometrical and physical requirements, and no other tenable hypothesis has been proposed, we hold that it assigns the true cause of universal gravitation.

(iii) Concluding remarks on the cause of gravitation.

1. In 1609 it was established by the researches of *Kepler*, from the planetary observations of *Tycho Brahe*, that the radius vector of a planet drawn to the centre of the sun sweeps over equal areas in equal times.

2. In composing the *Principia*, 1686, Sir *Isaac Newton* showed clearly that *Kepler's* law of areas indicates that the force which gives us the motions of the planets is central; and that it is only the incessant action of this central force which operates to curve the path of the planet at every point of its orbit. This led *Huyghens* and *Newton* to a valid theory of curvilinear motion, and thus marks an epoch in the science of natural philosophy.

3. During the three centuries since the discovery of the law of areas by *Kepler* and its mechanical and physical interpretation by *Newton*, it has been shown by all manner

of researches that this law of areas is a fundamental law of nature. Not only is it verified minutely in the motions of the planets and satellites of the solar system, by the most refined comparisons of theory with the most precise observational criteria which the state of modern astronomy affords; but also by researches on the orbits of nearly 100 visual double stars, and on the motions of an even greater number of spectroscopic binaries.

4. For more than a century the orbits of double stars justly have been regarded as affording the desired objective demonstration of the operation of the law of gravitation in sidereal systems. Having myself calculated about 60 orbits of known double stars and compared the results of gravitational theory with observation over long periods of time, I have not been able to detect the smallest deviation from the *Keplerian* law of areas or the *Newtonian* law of attraction in the motions of these stellar systems.

5. In two cases, indeed, namely: γ Ophiuchi and ζ Herculis, there is some evidence of disturbance of the *Keplerian* law of areas, as if due to a third body not yet detected by telescopic observation. Yet just as in the past history of astronomy, we had two analogous cases in the well known disturbed proper motions of Sirius and Procyon, — the companions of which have since been discovered by *Clark* and *Schaeberle*; — so also in this case the indications point to the triumph of the law of *Newton*. Thus the universality of the law of gravitation continues to be minutely verified by the most refined researches of modern astronomy.

6. In more than two centuries of the most recondite researches of astronomers and geometers not the slightest doubt has arisen that gravitation is a central force accurately directed to the centres of the revolving bodies. In the case of the motion of the moon about the earth, and of the earth about the sun we have calculated the strength of the stupendous cables of steel that would be required to hold these bodies in their orbits. All these calculations are easily verified.

7. The cause of universal gravitation is now definitely traced to wave-action in the aether, which is 689321600000 more elastic than air in proportion to its density. Wave-action directed to the sun in the foci of the conic sections described by the planets and comets alone will explain the central forces which hold these bodies in their orbits. And in stellar systems everywhere we see the same wave-action at work to fulfill *Kepler's* law of areas and *Newton's* law of force directed to the foci of the ellipses described by the stars. Thus we have developed a definite and absolute proof of the cause of gravitation, which is referred to waves in the aether, traveling with the velocity of light.

8. We have found that the geometrical theory of the equipotential surfaces, about two attracting masses, points unmistakably to the cause of gravitation. Vector composition for the forces observed to exist in the gravitational field about two equal stars shows that the aether is under tension between the bodies, and under increased pressure beyond them. Nothing but the wave-theory, with forces directed to the two centres occupied by the stars, will account for the observed form of the equipotential surfaces as shown in figure 15, which originally was drawn by *Thomson* and *Tait* for their celebrated *Treatise on natural philosophy*, 1873, yet unfortunately not

utilized by *Maxwell* in his attempt to explain gravitational stresses (*Treatise on electricity and magnetism*, 1873, chapter V, sections 103-111).

9. As *Maxwell* was misled into the conception of pressure in the direction of gravitational force, and tension at right angles thereto, instead of the reverse arrangement, the mathematical theory of this subject was given an unfortunate start; and the errors thus begun have been handed down by English writers, and the whole scientific world thus misled in a matter essentially simple. Nor is the difficulty diminished, but on the contrary notably increased, by the recent exploitation of the theory of relativity. Perhaps in time the valid dynamical theory of the *Principia* will again restore British science to a position worthy of the country-men of *Newton*.

10. That gravitation is propagated with the velocity of light is a necessary consequence of this wave-theory of physical forces. Under the vision of the physical world thus unfolded to our contemplation, the beauty and order of the universe appears truly remarkable; and we see that the new theory of the aether is a necessary path of exploration in attaining one of those summits near the stars. This sublimest portion of human knowledge still is only partly explored, but in rendering it more accessible to those who have long admired the marvelous geometry of the heavens, we have labored to extend the researches of Sir *Isaac Newton*.

11. It is well known that *Maxwell* was the first natural philosopher to attribute physical forces to stresses in the aethereal medium, but as he had not developed a theory of wave-action, as the mode of propagation for these forces he left the origin of the aether stresses quite obscure, as we see by the discussion in the closing section of his celebrated *Treatise on electricity and magnetism*, 1873.

»We have seen that the mathematical expressions for electrodynamic action led, in the mind of *Gauss*, to the conviction that a theory of the propagation of electric action in time would be found to be the very keystone of electro-dynamics. Now we are unable to conceive of propagation in time, except either as the flight of a material substance through space, or as the propagation of a condition of motion or stress in a medium already existing in space. In the theory of *Neumann*, the mathematical conception called potential, which we are unable to conceive as a material substance, is supposed to be projected from one particle to another, in a manner which is quite independent of a medium, and which, as *Neumann* has himself pointed out, is extremely different from that of the propagation of light. In the theories of *Riemann* and *Betti* it would appear that the action is supposed to be propagated in a manner somewhat more similar to that of light.«

»But in all of these theories the question naturally occurs: If something is transmitted from one particle to another at a distance, what is its condition after it has left the one particle and before it has reached the other? If this something is the potential energy of the two particles, as in *Neumann's* theory, how are we to conceive this energy as existing in a point of space, coinciding neither with the one particle nor with the other? In fact, whenever energy is transmitted from one body to another in time, there must be a medium or substance in which the energy exists after it leaves one

T. J. J. See. New Theory of the Aether.

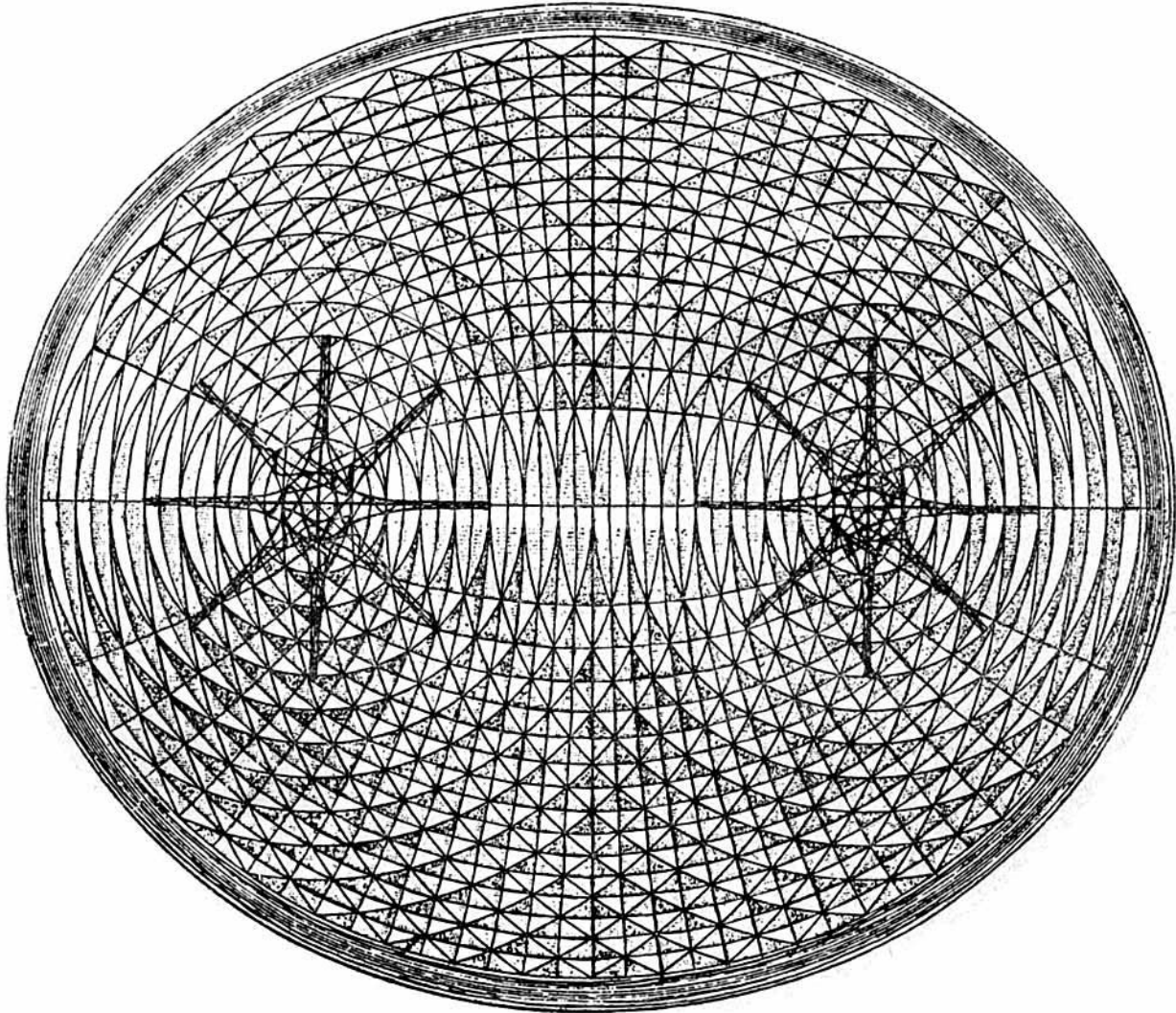

Fig. 19. Geometrical illustration of the wave-field about two equal stars. The wave-amplitudes increase asymptotically towards either body, which renders the aether of variable density $\sigma = \nu r$, while the wave-motion in concentric spheres, when reflected from the surfaces of the confocal ellipsoids, yields stresses along the tangents to the hyperboloids, which intersect the ellipsoids at right angles and with them constitute the system of confocal conics.

In nature the aether waves from the two centres are not reflected by the ellipsoidal surfaces, but proceed onward into infinite space; yet the reaction of the medium gives stresses along the tangents to the hyperboloids exactly the same as if the waves were perfectly reflected by the confocal ellipsoids, and the state of wave-motion rendered perpetual.

T. J. J. See. New Theory of the Aether.

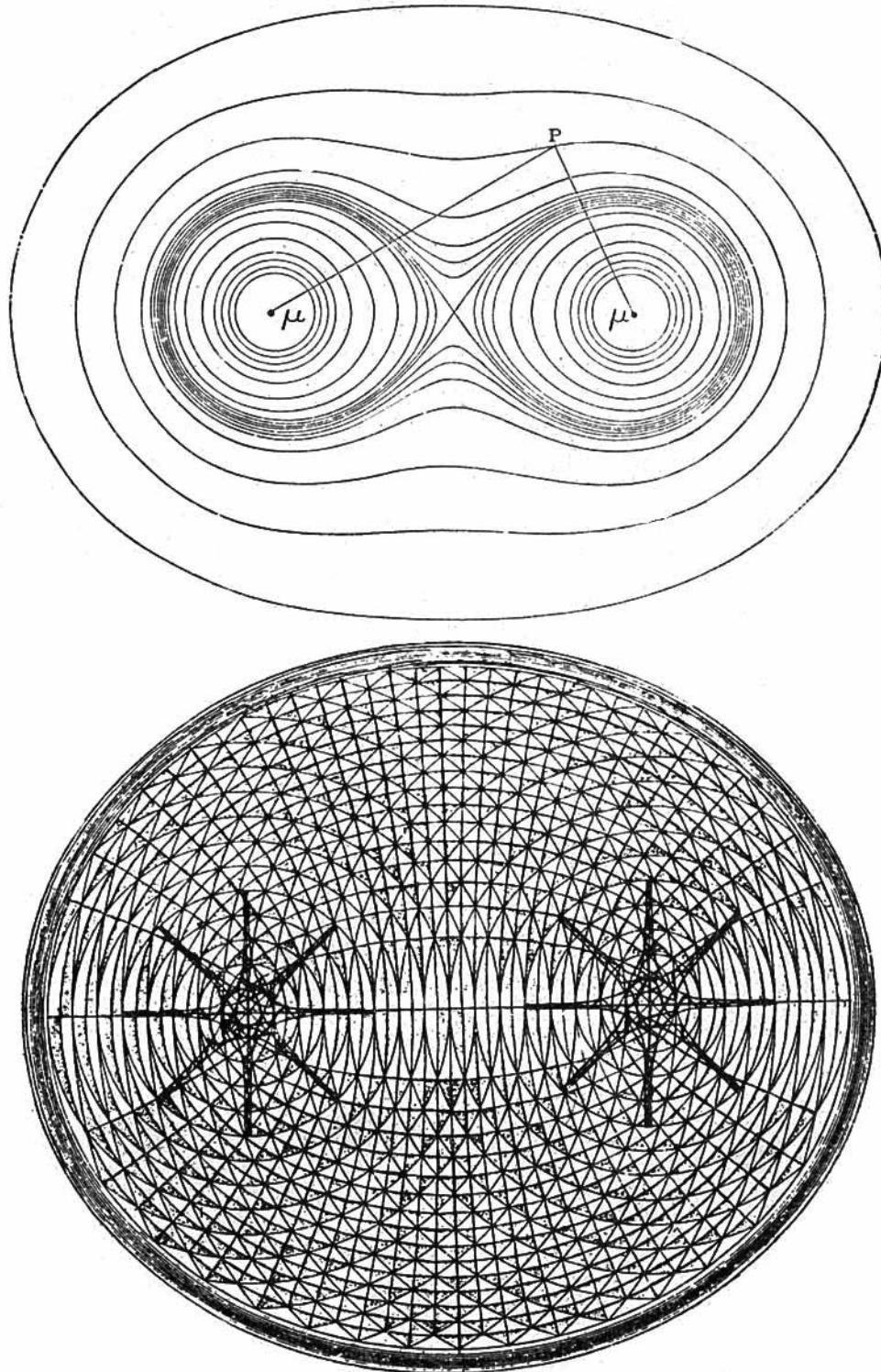

Fig. 20. Double plate showing the aether stresses in the wavefield about two equal stars:
 1. The equipotential surfaces distorted by gravitation to two centres, implying corresponding tension and pressure in the aether.
 2. The double wavefield showing the decrease of density of the aether towards either centre, and the stresses from infinite space acting along the hyperbolas for rendering the state of the medium perpetual.

body and before it reaches the other, for energy, as *Torricelli* remarked, is a quintessence of so subtle a nature that it cannot be contained in any vessel except the inmost substance of material things'. Hence all these theories lead to the conception of a medium in which the propagation takes place, and if we admit this medium as an hypothesis, I think it ought to occupy a prominent place in our investigations, and that we ought to endeavour to construct a mental representation of all the details of its action, and this has been my constant aim in this treatise.«

12. Accordingly, *Maxwell* held that we ought to endeavour to construct a mental representation of all the details of the action of the aetherial medium in producing the chief phenomena of nature. In the Electrodynamic wave-theory of physical forces, developed by the writer since 1914, we have attempted to construct this representation, for problems heretofore utterly bewildering to philosophers, and we venture to hope, with no inconsiderable success.

Nevertheless, in spite of our utmost effort, and the unexpected illumination thrown upon some of the greatest problems of transcendental physics, it is of course realized that the new theory of the aether remains in a very considerable degree incomplete.

In conclusion, it is a great pleasure to record the steadfast support lent to these researches by Mrs. *See*, and by Mr. *W. S. Trankle*, who have so lyally seconded our best efforts, which only too often seemed feeble and unequal to so daring an enterprise. It is only by departing from the beaten paths, in the pursuit of a valid theory of the luminiferous aether, that we hope to find the way towards light, more light!

In this sustained effort, which has now extended over seven years, the author's labors often have been relieved by the sympathetic reception accorded the results by several eminent colleagues who have confirmed the steps in this development. Commander *Leonard M. Cox*, Civil Engineer, U. S. N., Captain *Edward L. Beach*, U. S. N., Commandant at Mare Island, and Mr. *Otto von Geldern*, the eminent Civil Engineer, Vice-President of the California Academy of Sciences, San Francisco, have each shown such clear grasp of the new points of view as the work advanced, that it would be difficult to overrate the extent to which their enlightened interest has contributed to the final results.

Starlight on Loutre, Montgomery City, Missouri, 1921 May 6.

T. J. J. See.

Addition. Since concluding the above discussion my attention has been directed to a paper on certain physical experiments described at the General meeting of the American Philosophical Society, Philadelphia, April 19-23, 1921, by Dr. *Chas. F. Brush* of Cleveland, in which different gravitational effects were found for different substances. *Brush's* careful measurements are in marked contrast with those of Baron *Eötvös* of Budapest who found almost no variation of effects for different substances.

In this connection I call attention to the extraordinary negative gravitational measurements made by Professor *Francis E. Nipher* of Washington University, St. Louis, about two years ago. From his careful experiments *Nipher* concluded that the

gravitational property of a body depends upon its state of electric charge, and that up to the present time we know next to nothing of the potential of the earth's magnetic field.

In a postscript to the Third paper, (AN 5079, p. 301-2) I have directed attention to *Majorana's* remarkable experiments at Turin, 1919, showing loss of gravitational power when a body is screened by a layer of mercury.

The three experiments here cited may be interpreted in the light of the wave-theory, but I cannot see any other way of reconciling such unexpected experimental results, which run counter to all the old theories, and yet must be acknowledged as furnishing proof that gravitation is a phenomenon which may be experimentally modified, as by absorption, apparently of wave-action, by electric charges or other physical agency.

Accordingly all these new researches confirm the wave-theory experimentally and open up gravitation to physical investigation and experimentation. But in order to obtain new light on this difficult subject it is necessary to devise experiments which are conclusive.

1921 May 12.

T. J. J. See.

First postscript. In order to establish the error of a new theory it often is sufficient to show that it contradicts a more general and fundamental theory. In the present case we shall adopt in order to demonstrate the error of the *Einstein* theory the doctrine of the conservation of energy as the most general and fundamental principle of modern physical science.

1. Recently, in *Astron. Nachr.* No. 5115, Dr. *Grossmann* of Munich has examined anew the whole question of the motion of the perihelion of Mercury, according to *Newcomb's* work, and finds that the assumed value of $\delta\omega = +43''$ per century for the observed outstanding difference is not justified. Correcting the result by the equations for the meridian observations, the precision of which *Newcomb* distrusted, and bringing his result into accord with the definitive elements of the sun, by raising it $7''.35$, *Grossmann* concludes that the observed outstanding motion of Mercury's perihelion lies between $29''$ and $38''$, and thus in no case would attain the value of $43''$ demanded by *Einstein*.

In his researches on the observational material, Dr. *Grossmann* takes no account of the theoretical reduction, by *Weber's* Law, $\delta\omega = +14''.5$, which would make the outstanding motion still smaller, and more out of harmony with the *Einstein* requirements. Thus when tested by the best available data for the motion of Mercury the *Einstein*-theory does not satisfy modern astronomical observations.

2. In the 'Treatise on electricity and magnetism', section 856, *Maxwell* has successfully defended the validity of *Weber's* law, of which the potential is

$$V = k^2 m m' \cdot 1/r \cdot \{1 - (1/c^2)(dr/dt)^2\}. \quad (1)$$

The second term gives the effect due to motion in a wave-field, the work of transforming the potential energy changing like the kinetic energy, with the square of the planet's velocity relatively to the sun. If $dr/dt = 0$, as in circular orbits, the *Newtonian* law follows; but more generally the velocity in the direction of the radius vector dr/dt yields a term for the effect of induction, and d^2r/dt^2 gives the term

for the change of the induction, under motion in the wave-field. Thus *Weber's* law is the fundamental law of nature, and from (1) we have:

$$f = -\partial V/\partial r = k^2 m m' \cdot 1/r^2 \cdot \{1 - (1/c^2)(dr/dt)^2 + (2r/c^2) d^2r/dt^2\} \quad (2)$$

For it is well known in the theory of energy, that a planet may move from perihelion to aphelion, and vice versa, yet the whole energy in the conservative system remains absolutely constant. Thus we always have:

$$T + V = T - Mm/r = C$$

or $T + V = \frac{1}{2}m [(dx/dt)^2 + (dy/dt)^2 + (dz/dt)^2] - Mm[(x-x')^2 + (y-y')^2 + (z-z')^2]^{-1/2} = C. \quad (3)$

As the sun moves, as well as the planet, when the mass of the planet is sensible, we may write the more general expression for the kinetic energy of orbital motion about the centre of gravity of the system:

$$\frac{1}{2}M [mr/(M+m)]^2 \Omega^2 + \frac{1}{2}m [Mr/(M+m)]^2 \Omega^2 = T. \quad (4)$$

In equation (3) the negative term is the potential energy. When kinetic energy changes, in a way depending on v^2 , a corresponding change must occur in V , the potential energy, otherwise the sum of the two energies could not remain constant.

3. The following diagram represents the energy changes in the planetary motion, substantially as given by Professor *Kundt*, in his lectures on physics at the university of Berlin, according to *Helmholtz's* doctrine of the conservation of energy, 1847.

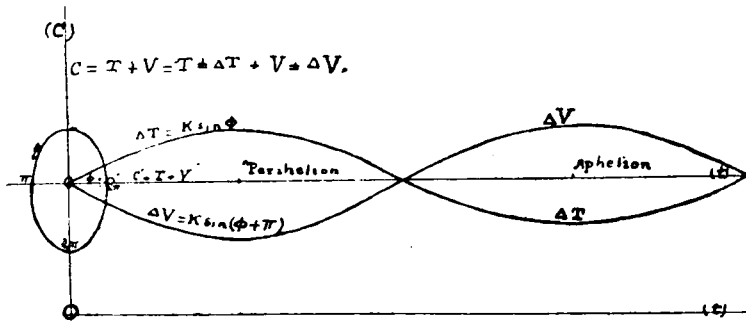

Fig. a.

We see by this diagram that the time flows on continuously as the planet oscillates from perihelion to aphelion, and the curve extends along the axis (t).

Meanwhile when the potential energy is a maximum at aphelion, $V' = V + \Delta V$, the kinetic energy is a minimum, $T' = T - \Delta T$, because ΔT is negative at aphelion, and numerically just equal to ΔV , which is then positive, as shown in the diagram.

At perihelion, on the other hand, the kinetic energy is a maximum, the potential energy a minimum, for corresponding reasons. The diagram, with two superposed sine curves, $\Delta T = K \sin \Phi$, and $\Delta V = K \sin(\Phi + \pi)$, everywhere exactly neutralizing each other, because differing in phase by π , will therefore correctly represent the oscillations of kinetic and potential energy in planetary motion, under a conservative system, free from collisions.

¹⁾ Since finishing the sixth paper, I have obtained new and most abundant observational proof that mass movements in the sun do send powerful wave disturbances to the earth, and by the resulting inductions thus produce the aurorae, earth currents and similar disturbances in the earth's wave-field.

4. Returning now to the *Gerber* formula, in comparison with the *Weber* formula, for the potential, we perceive that the *Weber* formula is correct, while the *Gerber* formula is incorrect. In the work of transformation the potential energy changes like the kinetic energy, with the square of the planet's velocity, relatively to the sun. Unless we admit this to be true we have to deny the conservation of energy; for no other result is possible by the first equation of (3).

Accordingly, the formula for the potential, under *Weber's* law

$$V = k^2 m m' \cdot (1/r) [1 - (1/c^2)(dr/dt)^2] \quad (5)$$

is valid and undeniably admissible. On the other hand, *Gerber's* formula for the potential

$$V = (M/r) \{1/[1 - (1/c)(dr/dt)^2]\} \quad (6)$$

is invalid and wholly inadmissible, because it violates the principle of the conservation of energy.

The *Gerber* formula being thus inadmissible, *Einstein's* theory, built upon it, necessarily falls to the ground. Thus it is definitely disproved, and can no longer be maintained by those who admit the conservation of energy.

5. If we seek to inquire into the nature of the wave-fields about two attracting bodies, we shall need to have recourse to the discussion in part II of the sixth paper on the New Theory of the Aether, where the whole problem is treated in some detail, and illustrated by figures showing the tension between the masses and increase of pressure beyond them. This argument is established by necessary and sufficient conditions. Such wave-fields¹⁾ and nothing else will explain the straight line action of the forces which govern the motions of the planets in their orbits.

It is needless to point out that as the aether is a kinetic medium, the physical basis of all forces, and nothing finer underlies it, it is the source and ultimate reservoir of all energy. Hence we see the physical basis of the conservation of energy. The kinetic theory of the aether thus leads to the conservation of energy, and any result in violation of this great principle must be unreservedly rejected. Accordingly we have a definite demonstration of the erroneous character of the *Einstein*

theory.

1921 Oct. 28.

T. J. J. See.

Second Postscript. Since finishing the body of this paper, in May, I have been impressed with the desirability of obtaining additional light on the forces which sustain the equilibrium of the molecules of an elastic solid. Heretofore this problem has not offered to investigators any very accessible point of attack. On December 10, however, it occurred to me how this problem could be solved, by a method of the required mathematical rigor, which at the same time conforms to the present state of our knowledge of experimental physics.

Hence we add a brief outline of this new method in the hope that it will be of interest to the readers of this series of papers on the new theory of the aether.

By way of extending the argument given in the fifth

paper, AN 5130, p. 330, and in the sixth paper above, equation (7), we notice:

1. The refractive action $(n^2 - 1)$ depends on the density of the solid σ , and the changing wave-length λ , and thus on some unknown function $\pi(\sigma/\lambda)$. But in a fixed mass the density varies inversely as the cube of the distance of the molecules, as in the formula for a sphere:

$$m = \frac{4}{3}\pi\sigma r^3 \quad \sigma = \frac{3}{4}m/\pi r^3 = C/r^3. \quad (\alpha)$$

Hence we may take $\pi(\sigma/\lambda)$ as a function of the molecular distance $\Phi_1(r) = C/r^3 = u$.

2. As regards the violence of the incessant bending of the wave-front, for waves coming from all directions, $\varphi(\beta)$, we notice that this effect likewise is a function of the density, and of the elasticity or rigidity, and thus of the atomic distances r ; yet as we do not know the nature of this dependence we simply write for $\varphi(\beta)$ an unknown function $\Phi_2(r) = v$.

3. In reference to the violence of the incessant dis-

$$(n^2 - 1) \pi(\sigma/\lambda) \varphi(\beta) \psi(\delta) \chi(\kappa) \theta(\rho \cdot e^{-\alpha}) = \Phi_1(r) \cdot \Phi_2(r) \cdot \Phi_3(r) \cdot \Phi_4(r) \cdot \Phi_5(r) = u \cdot v \cdot w \cdot u' \cdot v' = U. \quad (\beta)$$

The partial differentiation of this function of five variables relative to the three coordinates (x, y, z) yields:

$$\begin{aligned} dU = & (\partial U/\partial u \cdot \partial u/\partial x + \partial U/\partial v \cdot \partial v/\partial x + \partial U/\partial w \cdot \partial w/\partial x + \partial U/\partial u' \cdot \partial u'/\partial x + \partial U/\partial v' \cdot \partial v'/\partial x) dx \\ & + (\partial U/\partial u \cdot \partial u/\partial y + \partial U/\partial v \cdot \partial v/\partial y + \partial U/\partial w \cdot \partial w/\partial y + \partial U/\partial u' \cdot \partial u'/\partial y + \partial U/\partial v' \cdot \partial v'/\partial y) dy \\ & + (\partial U/\partial u \cdot \partial u/\partial z + \partial U/\partial v \cdot \partial v/\partial z + \partial U/\partial w \cdot \partial w/\partial z + \partial U/\partial u' \cdot \partial u'/\partial z + \partial U/\partial v' \cdot \partial v'/\partial z) dz. \end{aligned} \quad (\gamma)$$

7. To effect the required quintuple integration we should have to derive successively d^2U , d^3U , d^4U , d^5U ; and if the last function, or any one of them, was known, we could then, by the reverse process of integration, calculate U , and finally Ω . Unfortunately the finite expressions of these successive differentials are quite unknown; and thus it is useless to develop these differential coefficients.

Apparently the only way we can attack this problem successfully is to deduce the function U , for the action of the molecular forces, direct from the data supplied by the dynamical theory of gases.

This happens to yield an integral expression, the law of molecular repulsion being sensibly $f = \mu/r^5$, and hence we have a tangible mode of approach; and fortunately the theoretical conclusions are confirmed by experiments, which are adopted by the best authorities in the dynamical theory of gases.

8. Accordingly, our mode of integration reduces to

$$\Omega = \iiint \iiint \iiint \varepsilon d^5U dr dr dr dr dr \int \varpi(\omega) d\omega \quad (\delta)$$

$$= U \int \varepsilon \varpi(\omega) d\omega \quad (\epsilon)$$

$$= U \int \left\{ \partial \varepsilon / \partial u \cdot du + \partial \varepsilon / \partial v \cdot dv + \partial \varepsilon / \partial w \cdot dw + \partial \varepsilon / \partial u' \cdot du' + \partial \varepsilon / \partial v' \cdot dv' + \partial \varepsilon / \partial \omega \cdot d\omega \right\} \quad (\zeta)$$

$$= U \int d\varepsilon = U\varepsilon \quad (\eta)$$

where $\varepsilon = 689321600000$ the amount by which the elasticity of the aether exceeds that of the air in proportion to its density.

9. It will be shown below how the function U for the first five integrations may be obtained, in the integral form, corresponding to the repulsive forces actually observed in the theory of gases $f = \mu/r^5$, and the terms giving attraction at greater distances may be added. The sixth integral, for the central pressure due to the integration for the steady action of the enclosing sheath of partially disrupted waves of the aether, leads to the elastic constant of the aether, and thus presents no difficulty.

persion of these incident waves, $\psi(\delta)$, it appears that from the action of diamond on light this effect must depend mainly on the rigidity or hardness, and thus on some function of the radius of atomic action, $\Phi_3(r) = w$.

4. The crystalline arrangement and the forces involved in giving compactness to atoms combined in a way to be most effective, depend also on the atomic distances, or radii of molecular activity, and hence on some function of the distance $\Phi_4(r) = u'$.

5. The power of reflection of waves depends on the smoothness and rigidity of the reflecting mass, and thus on the atomic distances and the forces by which the structure is rendered rigid and impenetrable to the wave agitation. We may take this unknown function as $\Phi_5(r) = v'$.

6. Accordingly, it appears that the first five elements of the integral for Ω , in equation (108) of the fifth paper, or equation (7) above, reduce to

10. In 1866 *Maxwell* concluded from certain researches in the dynamical theory of gases, (Scientific Papers 2.32), that in the collisions of molecules the molecular forces, at very short range of action, are repulsive, and vary inversely as the 5th power of the distance, $f = \mu/r^5$. In the present writer's researches on the physical constitution of the sun and planets, (AN 3992, 4053, 4104, 4152), it is shown that gases and solids are closely related, through internal heat developing high elasticity and great effective rigidity, under the enormous pressure to which matter is subjected in the interior of the heavenly bodies.

11. In speaking of the effect of increasing temperature as we descend into the sun's interior, *Newcomb* long ago remarked (Encycl. Amer., article Sun, 1904) that two oppositely directed and very powerful forces were at work: »an inconceivable degree of heat, such that were matter exposed to it on the surface of the earth, it would explode with a violence to which nothing within our experience can be compared; and on the other hand the tremendous pressure due to the superincumbent layers, confining the matter which otherwise would expand with stupendous explosive violence. Owing to the high effective rigidity acquired by confined gaseous matter — the sun having an average effective rigidity from 2000 to 6000 times that of nickel-steel, — we have a valid point of attack for solids, as we shall now proceed to show in some detail.

12. It was long ago recognized by *Mossotti*, (Sur les forces qui régissent la constitution intérieure des corps, Turin, 1836) that at small distances the repulsive forces become more powerful than the attractive forces. Hence, in order to deal satisfactorily with molecular forces, we must have a function composed of several terms which becomes negative at very small distances, positive at greater distances, — all the distances remaining small absolutely, about the order of wave-lengths of light. This function, when integrated relatively

to the distances, should bring into play both attractive and repulsive forces, mutually balancing each other, and thus yielding the rigidity noticed in an elastic solid.

13. We therefore take the molecular forces to be represented by a potential of the form:

$$W = [(h-r)^2 - k/r^2]r_1^4. \quad (\theta)$$

Hence at such small distances the forces become

$$\begin{aligned} f &= \partial W / \partial r = [r - h + k/r^3]r_1^4 \quad (\epsilon) \\ &= [r^4 - hr^3 + k]r_1^4 = \\ &= [(r-r_1)(r-r_2)\{r-(a+ib)\}\{r-(a-ib)\}]r_1^4. \quad (\kappa) \end{aligned}$$

14. We are concerned only with very small distances, and therefore we introduce the condition that when $r=r_1=\lambda$, $f=0$; then we have to investigate the biquadratic between the distances r_1 to r_4 :

$$\begin{aligned} r^4 - hr^3 + k &= \\ = (r-r_1)(r-r_2)\{r-(a+ib)\}\{r-(a-ib)\} &= 0. \quad (\lambda) \end{aligned}$$

If any of the roots are real, which we here assume, it can be shown that the equation has two real roots, namely, r_1 , a maximum, at which the attractive forces vanish, $f=0$, and r_2 a smaller value at which the attractive forces are a maximum, as shown by the following diagram. The constant k is to be so adjusted that r_1 falls on the axis (r) making $f=0$. The condition for these two roots is the maximum and minimum of the potential W in (θ), $\partial W / \partial r = 0$, as in equation (λ).

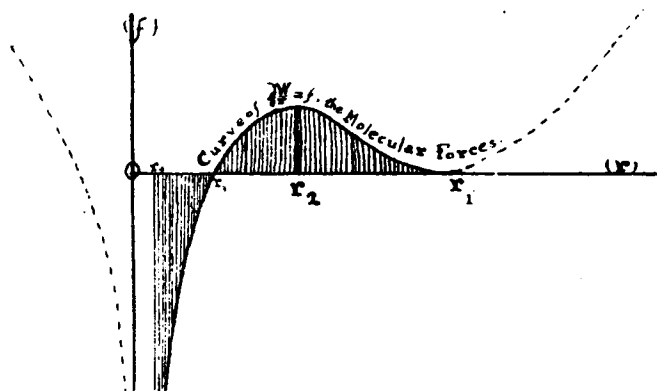

Fig. a. Illustration of the curve of molecular forces $\partial W / \partial r = f$, the unessential parts outside the limits r_1-r_4 being indicated by pointed lines.

15. As a solid body is the result of the equilibrium established between attractive and repulsive forces, we have to get the effect of these equilibrated forces by integrating the equation (ϵ) between proper limits:

$$f_e = \int_{r_4}^{r_1} \partial W / \partial r \cdot dr + c = \int_{r_4}^{r_1} (r^4 - hr^3 + k) dr + c = 0. \quad (\mu)$$

The nature of this integration is indicated by the above fig. a.

16. This equation (μ) contains the whole theory of the equilibrated forces in a solid body. The integral is

$$f_e = \int_{r_4}^{r_1} \partial W / \partial r \cdot dr + c = [1/5 r^5 - 1/4 h r^4 + k r]_{r_4}^{r_1} + c = 0 \quad (\nu)$$

which is an equation of the fifth degree in r , the variable distance over which the molecular forces act.

The nature of the curve to be integrated in fig. a depends on the value of h , a coefficient of hardness or rigidity. If this constant h is small, but not below a certain limit h_0 , corresponding to fluidity, the body will have slight tenacity, and tend to crumble, like stone, chalk or similar substances. If below h_0 , the body is fluid, and not solid at all.

As h increases above h_0 , we get a series of bodies of increasing hardness, as shown in Fig. b.

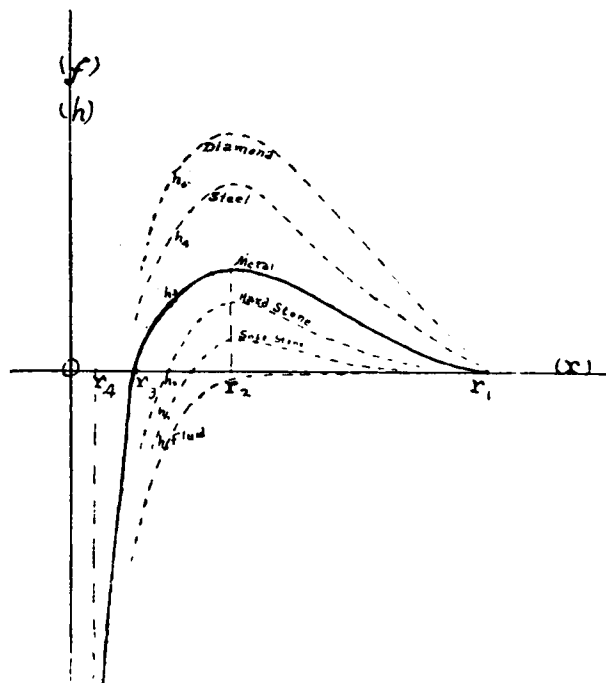

Fig. b.

17. In his celebrated memoir on the dynamical theory of gases, 1866, (Scient. Pap. 2.32) Maxwell remarks that the coefficient of rigidity = p , the pressure. He designates the elasticity by E and the density by ρ .

»This rigidity, however, cannot be directly observed, because the molecules continually deflect each other from their rectilinear courses, and so equalize the pressure in all directions. The rate at which this equalization takes place is great, but not infinite; and therefore there remains a certain inequality of pressure which constitutes the phenomenon of viscosity.«

»I have found by experiment that the coefficient of viscosity in a given gas is independent of the density, and proportional to the absolute temperature, so that if ET be the viscosity, $ET \sim p/\rho$.«

«But $E = p$, therefore T , the time of relaxation, varies inversely as the density and is independent of the temperature. Hence the number of collisions producing a given deflection which take place in unit of time is independent of the temperature, that is, of the velocity of the molecules, and is proportional to the number of molecules in unit of volume. If we suppose the molecules hard elastic bodies, the number of collisions of a given kind will be proportional to the velocity, but if we suppose them centres of force, the angle of deflection will be smaller when the velocity is greater; and if the force

is inversely as the fifth power of the distance, the number of deflections of a given kind will be independent of the velocity. Hence I have adopted this law in making my calculations.*

18. The problem of attractive and repulsive forces has been ably discussed by *Boltzmann* (Vorlesungen über Gas-Theorie, 1896, p. 160-161), who concurs in *Maxwell's* reasoning. *Boltzmann* finds his equations much simplified by taking $n = 4$, and then the repulsion between two molecules $f = K/r^{n+1}$, becomes of the inverse 5th power. He adds that his law appears to hold accurately for compound gases; (water vapor, H_2O , carbonic acid, CO_2), but not so satisfactorily for common gases (oxygen, hydrogen, nitrogen). Experience is too limited, he thinks, to make known the exact law in most cases.

»Wir sind daher weit entfernt, behaupten zu wollen, daß sich die Gasmoleküle wirklich wie Massenpunkte verhalten, zwischen denen eine der fünften Potenz der Entfernung verkehrt proportionale Abstoßung wirksam ist. Da es sich hier aber bloß um ein mechanisches Modell handelt, so nehmen wir jenes zuerst von *Maxwell* eingeführte Wirkungsgesetz an, für welches die Rechnung am einfachsten ist.«

In a footnote he adds:

»Auch die Annahme einer der fünften Potenz der Entfernung proportionalen Anziehung gestattet eine ähnliche Vereinfachung der Rechnung (vgl. Wien. Sitzungsber. 89.7 14, Mai 1884). Doch muß man dann annehmen, daß für Entfernungen, die noch klein gegen die Distanz sind, bei der schon starke Wirkung stattfindet, die Kraft ein anderes Gesetz befolgt, nach welchem die Anziehung endlich bleibt oder in Abstoßung übergeht, weil sonst die Moleküle beim Zusammenstoß sich nicht mehr in endlicher Zeit trennen. Im Texte wollen wir jedoch immer eine der fünften Potenz verkehrt proportionale Abstoßung annehmen.«

The latest researches by *Chapman* and *Jeans* (Dynamical theory of gases, 1916, p. 235-237, 256) leave the conclusions of *Maxwell* and *Boltzmann* unchanged, namely, in molecular collision the repulsive force is $f = \mu/r^5$. We are therefore justified in holding that the wave-theory gives rise to both attractive and repulsive forces, which are intelligibly united into a continuous mode of action only by a function of the kind dealt with above.

By means of the above function, however, we have an adequate theory of molecular forces. It accounts for solids of various degrees of hardness, with the other physical properties relating to molecular action and structure.

19. In the above equation (ν) we may divide through by r^5 and obtain

$$\left[\frac{1}{5} r^2 - \frac{1}{4} h r + k/r^2 + c/r^3 \right]_{r_1}^{r_4} = 0. \quad (\xi)$$

Now the arguments put forth by *Maxwell*, *Boltzmann*, *Jeans*, and others that for gases the repulsive forces, when the molecules are in collision, vary as μ/r^5 , would lead us to select the term c/r^3 as that which becomes very large when r is very small — the other terms being relatively insensible at the time of collision. The term k/r^2 would also become large, yet not so large as the last term depending on the inverse 5th power of r .

In order to perceive why there is both attraction and repulsion, we divide (ν) by r^3 only, and then we have:

$$\left[\frac{1}{5} r^2 - \frac{1}{4} h r + k/r^2 + c/r^3 \right]_{r_1}^{r_4} = 0. \quad (o)$$

This function is positive between r_1 and r_3 , but negative between r_3 and r_4 , as we see by the form of the curve in Fig. a.

The last term of (o) corresponds to the density function in equation (α) above.

20. In my researches on the internal constitution of the heavenly bodies, (AN 3992, 4053, 4104, 4152) I have shown that the sun's matter internally is under tremendous explosive forces, yet held in equilibrium by the gravitational pressure of the outer layers. If the pressure could be relieved, from this matter at the temperature of millions of degrees, it would, (as *Newcomb* remarked in 1904) explode with a violence surpassing that of dynamite or any known substance. Hence in confinement the matter is kept rigid by pressure; and in AN 4104, I have calculated that the average rigidity of the solar matter may be from 2000 to 6000 times that of nickel-steel.

Now the property of rigidity acquired by the sun's matter, as thus confined under tremendous pressure, is analogous to the rigidity of an ordinary solid, — with this difference, that in the ordinary solid heat is largely absent and the molecules thus come so close together that collisions are incessant, under the short waves pervading nature, and the Maxwellian repulsive forces thus arising balance and overcome the attractive forces. These two oppositely directed forces, both very powerful at the small distances, r_1 - r_4 , bind the molecules together into a solid, with hardness or rigidity depending on the coefficient h . If we heat a solid, the long heat waves cause the molecules to oscillate beyond the range of action r_1 - r_4 , and liquefaction and vaporization takes place.

This transformation of the equation (108) of the fifth paper, equation (ξ) above, makes it conform to the experience of *Maxwell*, *Boltzmann*, *Jeans*, and others in the dynamical theory of gases; and as we pass directly from the theory of a gas to that of a solid, by virtue of the researches on the constitution of the sun, we now have a theory of molecular forces which is concrete, and experimentally valid, namely:

$$\Omega = \left[\frac{1}{5} r^5 - \frac{1}{4} h r^4 + k r + c \right]_{r_1}^{r_4} \cdot \epsilon. \quad (\pi)$$

In virtue of the changes in r , the elastic force of the aether may be positive or negative and has the variation which generates the observed forces, or wave-stresses exerted by the aether upon matter, which usually is most powerful at the boundary owing to the changes of wave-action defined by *Poisson's* equation

$$\begin{aligned} \partial^2 \Phi / \partial t^2 &= a^2 (\partial^2 \Phi / \partial x^2 + \partial^2 \Phi / \partial y^2 + \partial^2 \Phi / \partial z^2); \\ \Phi &= f(x, y, z, t). \end{aligned} \quad (\rho)$$

In conclusion it only remains to add that the present developments in mathematical theory and in physical interpretation, are the outcome of many years of research, in which I have labored to give both a true and a sufficient explanation of the most varied natural phenomena. Doubtless very much remains to be done in the way of improvement, as shown also by the additions as the work progressed; but this refinement could not be entered upon till the first outline of the new theory of the aether was presented in continuous form.

In view of the vast extent of the field of research thus opened up to investigators, may we not hope that others will join in extending the discoveries here merely traversed in briefest outline?

The daring hope originally entertained by *Mossotti*, 1836, of analytically connecting the molecular forces directly with those of universal gravitation was long ago abandoned by investigators, chiefly because, as had been so strongly emphasized by *Laplace*, the molecular forces are sensible only at insensible distances, whereas the gravitational forces act with unbroken continuity over the immensity of the celestial spaces.

Maxwell was equally daring, and more fortunate in his physical conceptions, — when he emphasized the theory of the aether and concluded that all the forces observed in nature are due to stresses in this medium — but the theory of stresses never was completed, owing to the premature death

1921 Dec. 10.

of this eminent mathematician at the early age of 48. In fact *Maxwell* had not formulated any *modus operandi* as to how such stresses in the medium could arise, nor had he examined the elastic constant of the aether $\epsilon = 689321600000$.

In our new theory of the aether we have examined the character of this medium more critically than *Newton* and *Maxwell* had been able to do, and thus formulated a general theory of physical forces due to wave-action. This reduces the theory of aether-stresses to concrete form, and the procedure has the recommendation of simplicity. It also conforms to the undulatory theory of light and heat, and thus is a necessary step in the doctrine of continuity as applied to the physical universe. The subject is therefore inviting, and will appeal strongly to the geometer as well as the natural philosopher, who may now perceive a new physical basis for the geometrical forms observed in nature.

T. J. J. See.

Über die größte Phase von Sonnenfinsternissen. Von P. Harzer.

Die allgemein gebräuchliche Formel zur Verbesserung eines Näherungswertes τ der Zeit t der größten Phase, die in der *Hansenschen* Bezeichnung die Form

$$x = t - \tau = -15(m/m') \cos(M + M')$$

hat, ist ungenau. Wenn der Fehler der Formel auch nur auf etwa 17^s steigen kann, so ist gegen sie doch das einzuwenden, daß sie unter dem Anscheine der Strenge abgeleitet zu werden pflegt. Die genaue Formel habe ich, nachdem ich sie selbst aufgestellt hatte, in der mir hier zugänglichen Literatur überhaupt nur an einer Stelle (*Hansen*, Über die Verfinsterungen auf der Erde überhaupt, *Astr. Nachr.* B. 15, Nr. 339–342, S. 81, 82, Altona 1838) gefunden; selbst das Fundamentalwerk desselben Verfassers, die »Theorie der Sonnenfinsternisse und verwandten Erscheinungen« (*Abh. d. K. S. Ges. d. Wiss. B. IV*, Leipzig 1858), von dem man auf die frühere Abhandlung nicht leicht zurückgreifen wird, enthält nur die ungenaue Formel, und zwar leitet sie *Hansen* dort (S. 416) aus seinen genauen Formeln für die nördliche und südliche Grenzkurve ab, indem er ohne Begründung und ohne Verweisung auf die genaue Formel der früheren Abhandlung erklärt, »jetzt . . . abkürzen« zu wollen. Die Erinnerung an die genaue Formel ist anscheinend verloren gegangen; selbst *Th. v. Oppolzer* kennt sie nicht, da er in seinem »Canon der Finsternisse« (*Denkschr. d. math.-naturwiss. Cl. d. K. Ak. d. Wiss. B. LII*, S. XXIV, XXV, Wien 1887) für die größte Phase zunächst eine Umgestaltung der ungenauen Formel mitteilt, bei der ein weiterer Verlust an Genauigkeit eingetreten ist, sodann aber als »strenge *Hansensche* Formel« die ungenaue Formel angibt.

Die Quelle der ungenauen Formel ist meistens die unrichtige Bedingung, daß sich der Beobachtungsort zur Zeit der größten Phase in der geringsten Entfernung von der Achse des Schattenkegels befinde. Diese Bedingung habe ich zurückgreifend zuerst in der Inauguraldissertation von *Ursin* (*De eclipsi solari VII Sept. MDCCCXX* S. 14, Hafniae 1820) gefunden, in der *Ursin* mitteilt, daß er »*Gauß'sche* Methoden« mit der Zustimmung seines großen Lehrers habe benutzen dürfen. Daneben entsteht aber die ungenaue Formel auch durch eine unrichtige Einkleidung der richtigen Bedingung, daß die beiden Zeiten, zu denen bei beliebiger Phase der

Anfang und das Ende einer Finsternis eintritt, bei der größten Phase zusammenfallen. Die Verbesserung dieser Zeiten geschieht nämlich bei beliebig angenommener Phase nach den Formeln (»Theorie«, S. 413)

$$x = t - \tau = -15(m/m') \cos(M + M') + 15(u/m') \cos \chi'$$

Dabei gibt das letzte Glied, da die Größe χ' nur durch einen Sinus bestimmt wird, durch den Faktor $\cos \chi'$ zwei Werte von entgegengesetzten Vorzeichen, die für den Anfang und das Ende der Finsternis gelten. Man schließt hieraus (z. B. tut es *de Ball* in seinem Lehrbuche der sphärischen Astronomie, S. 339, Leipzig 1912), daß für die bei der größten Phase zusammenfallenden Werte der beiden Zeiten $\cos \chi' = 0$ sein müsse. Das ist aber unrichtig, und zwar deshalb, weil die Größe u , die in der Formel für x direkt und überdies indirekt, nämlich durch die Größe χ' eingeführt, vorkommt, von der Zeit abhängt und diese Abhängigkeit in einer Gleichung berücksichtigt werden muß, die für die Zeit eine Doppelwurzel haben soll und deshalb auch nach der Ableitung nach der Zeit noch gültig bleiben muß.

Im folgenden wollen wir eine einfache direkte Ableitung der Formeln für ein Extremum — nicht nur für ein Maximum — der Phase geben, die Art des Extremums untersuchen und Grenzen für den Fehler der ungenauen Formel aufstellen.

1. Durch den Beobachtungsort B legt man die nach dem Punkte Z der um B beschriebenen Himmelskugel zeigende z -Achse parallel zu der Richtung vom Mittelpunkte M des Mondes zum Mittelpunkte S der Sonne. Der Schnittpunkt C der Achse MS des Schattenkegels mit der senkrecht zur z -Achse durch B gelegten xy -Ebene ist der Mittelpunkt des Mondschattens in dieser Ebene, und dieser Schatten wird entsprechend der Annahme, daß der Mond und die Sonne Kugeln seien, als kreisförmig angesehen. Die Entfernung BC bezeichnen wir mit r , den Halbmesser des Schattens mit u , und zwar soll u allgemein nicht für den wirklichen Schatten gelten, sondern für denjenigen Schatten, den entsprechend der Phase i nicht die ganze Sonne erzeugt, sondern eine mit ihr konzentrische Kugel erzeugen würde, deren Halbmesser sich zu dem der Sonne wie $1 - 2i$ zu 1 verhielte. Es möge nun durch